

NAIMA CANADA

Guide to Near Net Zero Residential Buildings



Preface

The Guide to Near Net Zero Residential Buildings is published by NAIMA Canada. This guide consolidates information on how builders and designers may achieve the near net zero energy efficiency targets in current and upcoming codes, including the British Columbia Energy Step Code. This guide is intended to be an industry resource for designing and constructing low energy use buildings using mineral fibre insulation without compromising other aspects of building performance including moisture management, airtightness, and durability. This guide is limited to Part 9, wood-frame construction, with a focus on British Columbia, though the principles in this guide may be applied throughout Canada.

Disclaimer

This guide is provided for general information only. The greatest care has been taken to confirm the accuracy of the information contained herein. However, the authors, funders, publisher, and other contributors assume no liability for any damage, injury, loss, or expense that may be incurred or suffered as a result of the use of this publication, including products, building techniques, or practices. The views expressed herein do not necessarily represent those of any individual contributor, NAIMA Canada, CertainTeed, Johns Manville, Knauf Insulation, Owens Corning, ROCKWOOL, or the authors RDH Building Science.

Building science, products, and construction practices change and improve over time, and it is advisable to regularly consult up-to-date technical publications on building envelope science, products, and practices rather than relying solely on this publication. Seek specific information on the use of products, the requirements of good design and construction practices, and requirements of the applicable building codes before undertaking a construction project. Consult the manufacturer's instructions for construction products, and also speak with and retain consultants with appropriate engineering or architectural qualifications, and appropriate municipal and other authorities, regarding issues of design and construction practices, including fire protection.

The effective R-value ranges and assemblies illustrated in this guide represent potential strategies to reach high performance targets such as near net zero and the upper steps of the BC Energy Step Code. As with any performance-based energy target, energy modelling should be used to determine appropriate designs for each individual project. Compliance strategies may be impacted by design choices such as form factor, window placement, orientation, mechanical systems, and equipment efficiency.



Produced By:

RDH Building Science Inc.



Near Net Zero: A building with low energy usage such that it approaches the annual energy consumption of Net Zero Energy buildings, and, with additional measures, could produce nearly as much renewable energy as it uses on an annual basis.

Net Zero Energy Ready: A building with low energy usage such that, with additional measures, it could generate as much renewable energy as it uses on an annual basis.

Net Zero Energy: A building with low energy usage such that, with the use of active energy generation equipment, it can generate as much renewable energy as it uses on an annual basis.

Executive Summary

A near net zero building is one whose annual energy requirements are minimized and could be partially or completely offset by renewable energy. Its energy use is reduced to very low levels compared to traditional construction by using energy-efficient design solutions for all aspects of the building. New performance-based codes and targets for building energy efficiency, such as the BC Energy Step Code, allow for many potential solutions to reaching near net zero.

While the necessary thermal performance of the building enclosure depends on factors like climate zone, airtightness, window-to-wall ratio, building shape, size and orientation, and mechanical systems used, a well-insulated building enclosure as part of the **enclosure-first approach** enables both high performance and design flexibility. Increased airtightness, high effective R-values, and minimized thermal bridging are reliable design solutions for meeting near net zero targets.

A home built to near net zero targets, with a high-performance, thermally efficient enclosure, provides the end user with a noticeable increase in comfort and a durable building. It will also be more resilient to potential climate changes and more likely to align with future code updates.

This guide will instruct the user on how to design and build a future-proof near net zero building using existing, low cost, proven building materials and methods. This guide provides an outline of the principles of designing and constructing a near net zero energy efficient home, including,

- › Design optimization through energy modelling
- › Considerations for constructibility and cost
- › Solutions that focus on the increased thermal performance of the enclosure, without compromising other aspects of enclosure performance, including moisture management, airtightness, and durability
- › Energy savings

Remi Charron (Remi Charron Consulting Services) evaluated close to 2 million HOT2000 models using NRCan's Housing Technology Assessment Platform (HTAP) to support the development of the BC Energy Step Code. He leveraged this experience and conducted additional modelling to establish potential design strategies that can achieve the upper steps of the BC Energy Step Code (Steps 4 & 5) as well as net zero performance per the Canadian Home Builders' Association's net zero home guidelines. The successful design strategies modelled by Remi Charron were combined with industry experience by RDH Building Science to determine value-optimized enclosure performance. Beyond strictly construction cost, optimization for value was determined by also considering each enclosure assembly's effect on occupant comfort, overall constructibility, and end-user operation cost.

Ranges of effective insulation levels needed to meet near net zero targets are given for above-grade walls, below-grade assemblies, and roofs in all climate zones of British Columbia, with the upper steps of the BC Energy Step Code used as example targets. Considerations for other regions of Canada are also included. This guide will help the reader understand how the building enclosure plays an important role in overall building energy performance optimization for reaching near net zero energy efficiency performance targets.

Eight examples of near net zero assemblies, for above-grade walls, below-grade walls and roofs, are outlined in this guide, including key performance items and construction considerations. The corresponding effective R-values are given for each, showing the range in insulation performance that can be achieved with different insulation types and thicknesses. Five example details are shown to highlight the important aspects of transitions between assemblies that maintain airtightness and insulation continuity.

Enclosure-First Approach: A building design and construction approach to reducing building energy consumption with a focus on improving the effective thermal performance and airtightness of the building enclosure. It is a key strategy in achieving high-performance and near net zero buildings.

Mineral Fibre: Defined by the ULC as "an inorganic, non-metallic vitreous fibre manufactured from rock, slag or glass compositions"

Contents

- Near Net Zero Design & Code Compliance 1**
 - The BC Energy Step Code 1
 - Step Code Metrics. 1
 - BC Climate Zones 2
 - Step Code Targets. 3

- Benefits of Near Net Zero Construction. 4**
 - Occupant Comfort 4
 - Future-Proof Construction 5

- Performance Path & Energy Modelling 6**
 - Potential Pathways To Reaching Near Net Zero 6
 - Energy Modelling for Thermal Performance and Value-Optimization 6
 - Recommended Effective R-values to Reach Near Net Zero - BC and Across Canada 7

- Near Net Zero Design: The Enclosure-First Approach 8**
 - Minimize Heating/ Cooling Demand 8
 - Airtightness 8
 - Thermal Insulation 9
 - Enclosure Durability11

- Near Net Zero to Net Zero 14**
 - Required Amount of PV for Net Zero14

- Near Net Zero Above-Grade Wall Assemblies 15**
 - Split-Insulated Stud Wall15
 - Interior-Insulated Deep Stud Wall17
 - Near Net Zero Roof Assemblies19
 - Interior-Insulated Vented Attic Roof.19
 - Interior-Insulated Vented Vaulted Roof.21
 - Split-Insulated Low-Slope Roof23

- Near Net Zero Below-Grade Assemblies 25**
 - Exterior-Insulated Foundation Wall25
 - Exterior-Insulated Floor Slab27

- Example Near Net Zero Building Details 29**
 - Important Detailing Considerations.29
 - Detail 1: Interior-Insulated Attic Roof to Split-Insulated Wall31
 - Detail 2: Interior-Insulated Attic Roof to Interior-Insulated Deep Stud Wall.32
 - Detail 3: Split-Insulated Wall to Exterior-Insulated Foundation Wall33
 - Detail 4: Interior-Insulated Deep Stud Wall to Exterior/Split-Insulated Foundation Wall34
 - Detail 5: Exterior-Insulated Foundation Wall to Exterior-Insulated Floor Slab35

- Additional Resources. 36**

Near Net Zero Design & Code Compliance

While many standards and tools exist for designing an energy-efficient near net zero building, the new BC Energy Step Code (the Step Code) is an excellent basis for understanding performance-based energy efficiency metrics and targets. It is a voluntary performance path which is currently being implemented in many municipalities throughout BC, and provides a potential framework for improved building energy efficiency for the rest of Canada and a potential pathway to Canada-wide near net zero new construction.

The BC Energy Step Code

The Step Code is an energy efficiency compliance path designed to help both government and industry achieve a future in which all new construction across the province is near net zero by 2032. The path to net-zero energy ready is set through incremental building performance requirements. The upper steps of the Step Code are considered near net zero or net zero energy ready, particularly for Step 5.

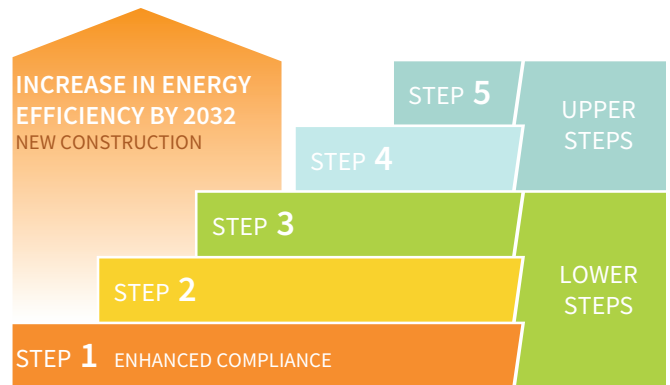

BC Energy Step Code performance-based energy efficiency steps for Part 9 buildings, with improving energy performance targets (i.e. reduction in building energy use) set out in up to five steps, planned for complete implementation by 2032.

Step Code Metrics

Step Code performance requirements can be separated into three main categories:



ACH

› **Airtightness** – Measured in **Air Changes per Hour** at 50 Pascals (ACH), it is the amount of air leakage across the enclosure of a building, commonly referred to as “air leakage rate”. Higher airtightness can result in improved durability and greater condensation and rain penetration control. Airtightness has also been determined to be one of most cost-effective ways to reduce building heating and cooling energy use, and testing is required for all steps of the Step Code.



TEDI

› **Thermal Energy Demand Intensity** – The Thermal Energy Demand Intensity (TEDI) metric addresses energy gains and losses through the building enclosure. TEDI limits the annual heating required by the building for space conditioning and for conditioning of ventilation air, estimated by using an energy model, normalized per square metre of area of conditioned space and expressed in kWh/(m²·year). TEDI considers thermal transmittance of the building enclosure components (including assemblies, windows, doors, and skylights), solar heat gains through building enclosure components, air leakage through the air barrier system, internal heat gains from occupants and equipment, and heat recovery from exhaust ventilation.



% < REF

› **Equipment and Systems** – Measures the energy consumption from mechanical systems including domestic hot water, pumps, and fans, omitting base loads such as plug-loads and lighting for Part 9 buildings. The metrics for equipment and system energy use are:

› **% Lower than Reference House** (% < REF) – uses comparative analysis of the proposed buildings mechanical energy use intensity versus that of a reference building (reference house). The mechanical energy use of the reference building and the proposed building is determined by energy modelling.



MEUI

› **Mechanical Energy Use Intensity** (MEUI) – is the metric for mechanical and systems energy use over a year. It is estimated by using an energy model normalized per square metre of area of conditioned space, and expressed in kWh/(m²·year).

BC Climate Zones

The Step Code defines the energy performance targets of a building based on the climate zone (CZ) where the building is located in. The BC climate zones are defined by the average heating degree days (HDD) below 18° C. The BC Building Code states that the authority having jurisdiction (AHJ) can establish climatic values to define climate zones, typically based on information from Environment Canada, and building designers must consult the AHJ before making any assumptions about a building's climate zone. Note that in some locations, there may be several climate zones due to variations in elevation.

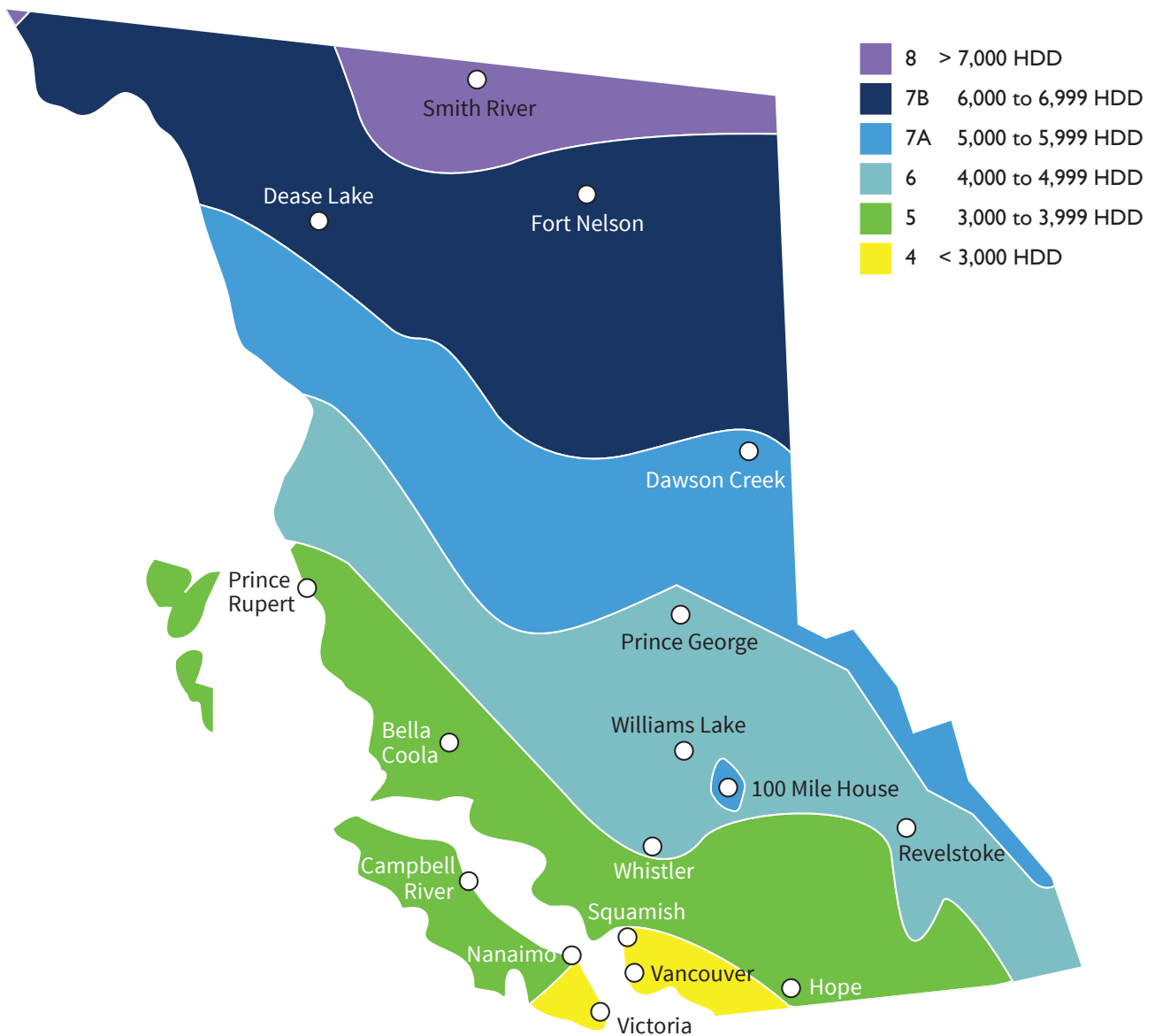

British Columbia climate zone map based on BC Building Code Appendix C climatic design data

Step Code Targets

For simplicity, the specific Step Code targets for equipment and systems (% <REF and MEUI) are omitted, since this guide is focused on enclosure-based targets and solutions for code compliance and reaching near net zero. See *the BC Energy Step Code Builder Guide* for more details on the metrics and compliance pathways of the Step Code.

Requirements for Part 9 Buildings Located in CZ 4			Requirements for Part 9 Buildings Located in CZ 5		
					
	ACH 50	TEDI		ACH 50	TEDI
STEP 1	*		STEP 1	*	
STEP 2	≤ 3.0	35	STEP 2	≤ 3.0	45
STEP 3	≤ 2.5	30	STEP 3	≤ 2.5	40
STEP 4	≤ 1.5	20	STEP 4	≤ 1.5	30
STEP 5**	≤ 1.0	15	STEP 5**	≤ 1.0	20

Requirements for Part 9 Buildings Located in CZ 6			Requirements for Part 9 Buildings Located in CZ 7A		
					
	ACH 50	TEDI		ACH 50	TEDI
STEP 1	*		STEP 1	*	
STEP 2	≤ 3.0	60	STEP 2	≤ 3.0	80
STEP 3	≤ 2.5	50	STEP 3	≤ 2.5	70
STEP 4	≤ 1.5	40	STEP 4	≤ 1.5	55
STEP 5**	≤ 1.0	25	STEP 5**	≤ 1.0	35

Requirements for Part 9 Buildings Located in CZ 7B			Requirements for Part 9 Buildings Located in CZ 8		
					
	ACH 50	TEDI		ACH 50	TEDI
STEP 1	*		STEP 1	*	
STEP 2	≤ 3.0	100	STEP 2	≤ 3.0	120
STEP 3	≤ 2.5	90	STEP 3	≤ 2.5	105
STEP 4	≤ 1.5	65	STEP 4	≤ 1.5	80
STEP 5**	≤ 1.0	50	STEP 5**	≤ 1.0	60

*There are no prescriptive minimum airtightness requirements for Step 1, but the building airtightness must still be tested and reported.

**Future-proof construction requirements.

Benefits of Near Net Zero Construction

High-performance buildings have many benefits, which include:

- › Improved occupant comfort and indoor air quality (see below):
 - › Reduced drafts from air leakage
 - › Stable and uniform ambient interior temperatures due to higher-performance enclosure assemblies
 - › Solar shading and natural ventilation can reduce the potential for overheating
 - › Continuously ventilated and filtered air with the use of heat recovery ventilators
 - › Reduced risk of mould growth caused by condensation on cold surfaces
- › Future-proof construction (see next page):
 - › Mandatory home energy labelling program is being implemented as part of the *Pan-Canadian Framework on Clean Growth and Climate Change* by the Government of Canada
- › Climate adaptation/climate change resilience:
 - › High-performance enclosures can withstand the effects of severe seasonal temperatures
 - › Less dependence on grid infrastructure increases public safety during times of crisis and natural disasters
 - › Carbon abatement from lower emissions may reduce the impact on climate change
 - › Indoor temperatures sustained longer in the event of power outages
- › Reduced energy consumption and the opportunity for lower utility bills
- › Lower greenhouse gas emissions:
 - › Less combustion of fossil fuels and lower demand for electricity generation (and corresponding environmental impacts)

Many of these benefits are dealt with extensively throughout this guide. Occupant comfort and future-proofing are discussed briefly below.

Occupant Comfort

High-performance buildings result in comfortable interior environments throughout the year. Highly insulated and airtight assemblies result in warmer interior surfaces and uniform indoor temperatures. For example, continuous exterior insulation minimizes potential cold spots on interior surfaces often found at framing locations like studs, top and bottom plates, and framing around openings. Thermally efficient and over-insulated doors and windows also results in warmer interior frame surface temperatures, increasing interior comfort.

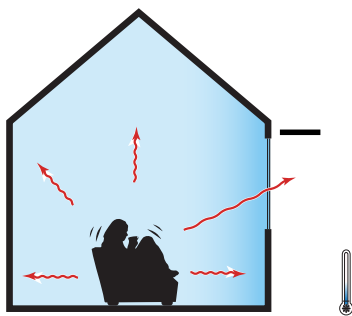

Poorly insulated and air leaky building, thermally uncomfortable

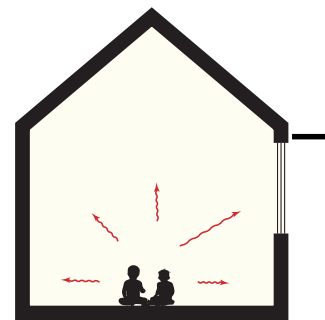

Highly insulated and airtight building, thermally comfortable

Future-Proof Construction

An enclosure-first design approach is part of an effective strategy to future-proof against both future building retrofit energy policies and increasingly severe climate events.

As the new construction building codes in BC and the rest of Canada move further toward net zero energy (e.g. the BC Energy Step Code, Toronto Green Standard), this leaves existing buildings as the next area of focus for policy on emission reduction and energy efficiency. Some municipalities and provinces/territories have already begun implementing energy upgrade requirements for retrofit projects (e.g. City of Vancouver). It is anticipated that building codes and by-laws throughout Canada will increasingly require energy upgrades for existing buildings, potentially setting performance targets for certain building types with a schedule for enforcement. Building near net zero homes is one way to future-proof against potential future energy retrofit policies, and also protect against rising energy costs and carbon tax.

The Government of Canada has plans to implement a mandatory home energy labelling program as part of ongoing climate action work. See the *Pan-Canadian-Framework on Clean Growth and Climate Change*, Built Environment section published by the Government of Canada. This means that all homes sold will have an EnerGuide label summarizing their energy efficiency and overall performance. Homes built now to Step 5 will have a better label than homes built to the code minimum and will be more attractive to home buyers. Additionally, by 2032 the code minimum in BC will be Step 5, meaning that selling a home that was built to lower performance requirements may be harder as the EnerGuide label will indicate the home is below the code minimum. To sell these "below code minimum" homes in 2032 the seller may need to lower the price or undergo expensive deep-energy retrofits to bring the home up to Step 5 code requirements.

Additionally, projections for climate change due to global warming include increased frequency and severity of extreme weather events and storms [IPCC, 2018]. Using an enclosure-first design approach decreases reliance on grid energy distribution systems that may be interrupted during severe weather events. For example, electricity service may be interrupted by blackouts due to strong winds and fallen trees, and some hydro power facilities may have lower capacity during droughts. Natural gas service may be disrupted during severe storms and heavy rainfall can damage buried utilities. Homes with high-performance enclosure designs have lower heating and cooling energy demand than typical construction, so occupants are not only more comfortable during times of emergency when utilities are not available, but also safer.

In addition to more insulated enclosures to reduce space conditioning energy demand, strategies to prevent overheating should be also be considered. Passive design measures like solar shading, natural ventilation, and controlling solar gain can help mitigate increasing temperatures (and/or the use of a mechanical cooling system). In the event of a power outage, homes that are built with these measures could stay cooler longer in the summer and warmer longer in the winter. Other climate adaptation strategies may also be considered such as **HRVs** with accessible filters for smoke control to combat the increase in forest fires. The use of HRVs with filters also leads to increased indoor air quality.

Pan-Canadian-Framework on Clean Growth and Climate Change (PCF): Is the Government of Canada's plan to meet emission reduction targets, grow the economy, and build resilience to a changing climate. It includes a pan-Canadian approach to pricing carbon pollution, and measures to achieve reductions across all sectors of the economy. It also includes actions to advance climate change adaptation and build resilience to climate impacts across the country.

Heat/Energy Recovery Ventilator (HRV/ERV): An active building ventilation appliance that uses a passive heat exchanger element to transfer heat between outgoing exhaust and incoming supply air streams within the ventilation unit. Supply air is typically ducted directly to each living area, and exhaust air from bathrooms and kitchens.

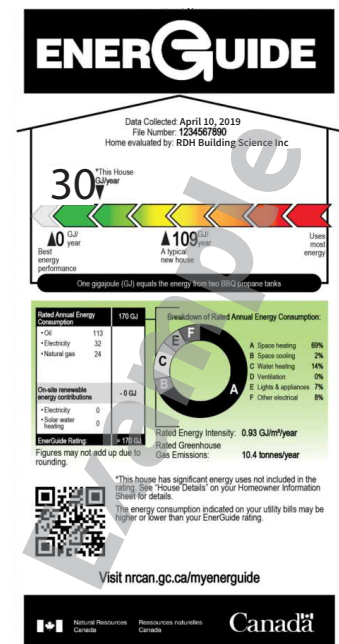

Example EnerGuide home energy label

Performance Path & Energy Modelling

Performance-based energy efficiency metrics allow buildings to use a wider variety of design and construction solutions compared to prescriptive metrics. Energy modelling must be used to explore the most appropriate way to reduce the building's energy use to near net zero levels. Once the building is constructed, commissioning and airtightness testing are also part of ensuring compliance with performance-based metrics.

Potential Pathways To Reaching Near Net Zero

Near net zero building requirements can be achieved using:

- › Optimized building shape and size with a simple form and well-placed openings:
 - › A building with several complex junctions and corners and increased enclosure area will allow far more heat transfer through the enclosure than a building that has been designed as a simple form.
- › Well-insulated assemblies with minimal thermal bridging for an overall thermally efficient building enclosure:
 - › Continuous exterior rigid mineral fibre insulation or deep interior-insulated assemblies are a good starting point for near net zero buildings (see pages 31-35)
- › A durable, airtight building enclosure
- › Thermally efficient windows, doors, and skylights
- › High-efficiency mechanical and electrical equipment
- › Photovoltaic/ solar energy generation system

Note: renewable energy generation is not applicable to Step Code compliance

Energy Modelling for Thermal Performance and Value-Optimization

The R-value ranges and assemblies shown in this guide as examples for reaching near net zero are based on a combination of energy modelling and industry experience. Energy modelling was conducted to establish potential design strategies to achieve the upper steps of the BC Energy Step Code (Steps 4 and 5) as well as net zero performance per the Canadian Home Builders' Association guidelines. The successful design strategies were combined with industry experience to determine value-optimized enclosure performance. Beyond strictly construction cost, optimization for value was determined by also considering each assembly's effect on occupant comfort, overall constructibility, and end-user operation cost. The value-optimization also considered the climate zone the building is located in, which may necessitate wall and roof assemblies with higher minimum effective R-values due to colder conditions, regardless of potential trade-offs that may be available.

The following page shows an illustrated map of Canada with climate zones noted and potential effective R-value ranges for the roof, walls, and below grade assemblies that may be considered when designing to reach near net zero. The ranges given demonstrate the wide variation based on the optimization pathway used to reach near net zero (i.e., trade-offs with mechanical systems and other building elements).

Energy Modelling: A computer-based mathematical replication of aspects of a building, including its overall shape and size, enclosure thermal performance and airtightness, and mechanical systems usage and efficiencies. Building energy modelling is used to quantify the energy use of a building using standardized operation parameters and climate conditions. Energy modelling is also part of the building design process, where theoretical modifications can be tested for their impact on overall energy usage, and for showing building code compliance.

Recommended Effective R-values to Reach Net Zero - BC and Across Canada

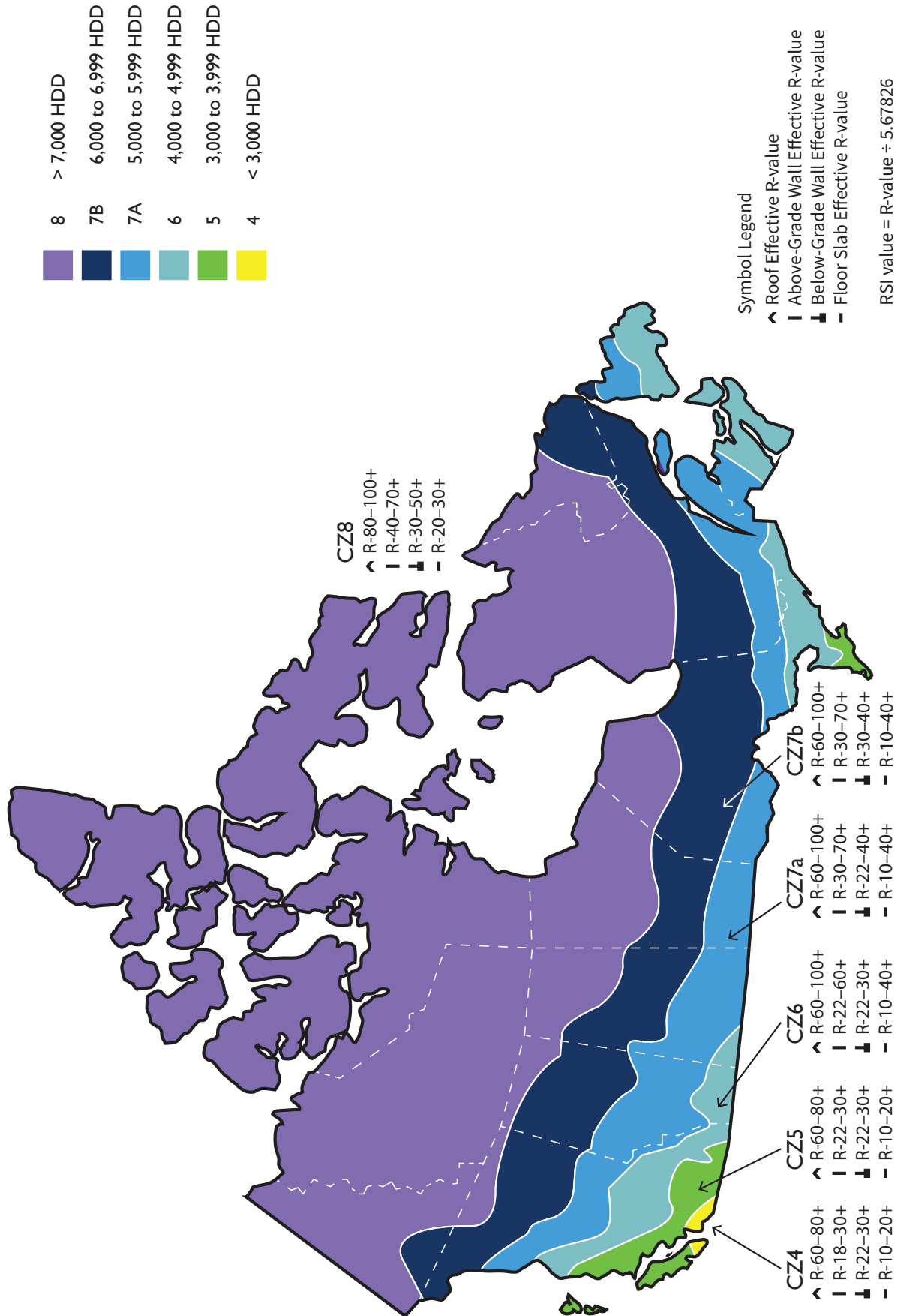

Near Net Zero Design: The Enclosure-First Approach

Minimize Heating/ Cooling Demand

The enclosure-first approach reduces energy consumption and provides a comfortable indoor environment for the occupants. A key strategy in achieving high-performance buildings is the use of well-insulated assemblies. These assemblies use insulation with minimal thermal bridging to resist heat loss or gain to lower the overall mechanical heating or cooling load. The enclosure components in a high-performance building, e.g., windows and doors, are also thermally efficient to control heat loss and gain. The restriction of air movement (i.e. air leakage through the enclosure) by the air barrier system is one of the most important functions of the building enclosure. Uncontrolled air leakage results in excessive heat loss that leads to thermal discomfort and energy waste, and can lead to moisture issues within the building enclosure. Besides improving the energy efficiency of the building, an enclosure-first approach can also contribute to better occupant comfort, since the building will allow less uncontrolled airflow and will have warmer interior surfaces and a more uniform indoor air temperature.

Airtightness

The design of an airtight assembly requires the use of appropriate materials, components, and accessories that can be combined to create an effective air barrier system. Ensuring continuity of the air barrier at interfaces and penetrations of the building enclosure is challenging and critical to its performance.

An effective air barrier should have the following features:

- ▶ **Air impermeability** - All materials, components, and accessories used to create the air barrier must be able to prevent airflow. This is typically defined in industry standards referenced by the BC Building Code as an air permeability of less than $0.02 \text{ L/s}\cdot\text{m}^2$ ($0.004 \text{ cfm}/\text{ft}^2$) at 75 Pa.
- ▶ **Continuity** - The air barrier system must completely enclose the conditioned space without any gaps or interruptions. Continuity is the most important criteria for an effective air barrier and also one of the most challenging. Designers and contractors must ensure continuity of the air barrier around penetrations, transitions, and interfaces in the enclosure. This can be done through proper detailing and diligent construction practices.
- ▶ **Durability** - The air barrier system must be designed to last for the entire service life of the building or of the materials that cover it. The system should resist mechanical forces, UV exposure, moisture, chemicals, and other contaminants, throughout its expected service life. Interfaces in particular should be designed to be resilient and able to accommodate expected deflections, for example at floor slabs.
- ▶ **Strength and stiffness** - From construction to occupancy, the air barrier system must resist forces acting on it. The design should account for mechanical forces created by wind and stack effect pressures and allow for dimensional changes in the structure caused by thermal expansion and moisture absorption.

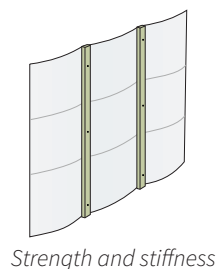
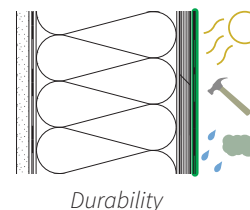
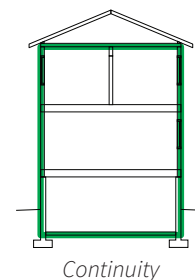
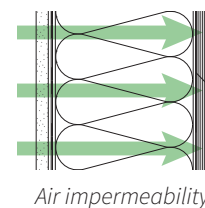

Thermal Insulation

The design of a thermally resistant assembly requires the use of materials and components with low thermal conductivities that are combined to create a continuous thermal insulation layer. Continuity of the thermal insulation is crucial to achieving maximized effective assembly thermal resistance. Only materials with high thermal resistances or low thermal conductivities (good thermal performance) should be used as part of the thermal insulation layer. All materials and components of the enclosure assembly must be accounted for in the calculation of its effective R-value.

As shown on the climate zone map of Canada on page 7, the range of effective R-values that can be used varies widely. Increasing the thickness of the insulation and focusing on continuity, especially at details and transitions, is the best way to increase the effective R-value of the assembly. Current standard assemblies have to be adjusted to accommodate greater thickness of the insulation as shown below, though the overall construction approach can often remain unchanged.

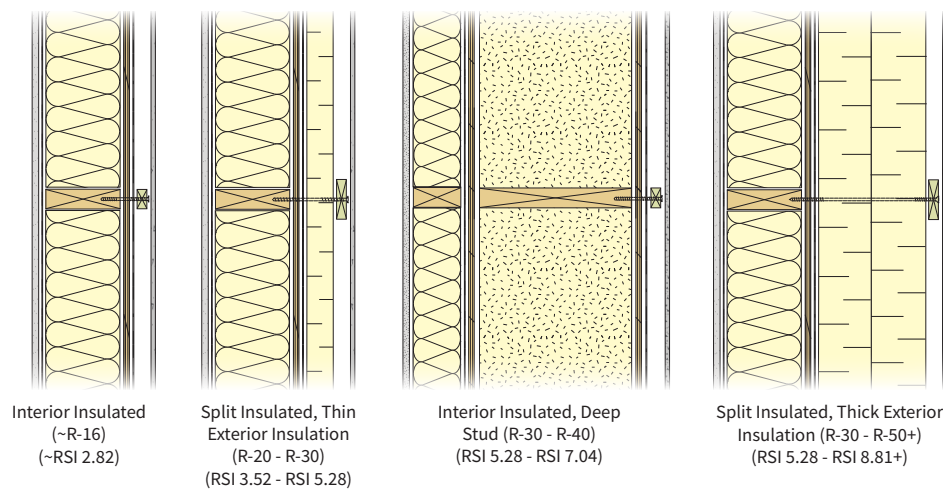

Example thermal insulation improvements to reach near net zero: conventional 2x6 and 2x4 wood-frame wall assemblies can often remain as the structural basis, but additional insulation will have to be accommodated within the assembly or at the exterior face.

Exterior Insulation and the Importance of Continuous Thermal Barriers

The use of continuous exterior insulation over structural framing is an easy way to improve the effective R-value of an assembly and to minimize the effects of **thermal bridging**. The exterior insulation product used must not be sensitive to moisture, as it will be exposed to periodic wetting. The continuity of thermal barriers should be considered while detailing, especially at interfaces between assemblies. Heat will travel most through the path of least resistance, meaning that gaps or conductive materials used as part of the thermal barrier will result in greatly reduced effective R-values. Conductive materials like metal that penetrate the thermal barrier lead to heat loss and potential durability issues. These thermal bridges should be avoided and/or reduced to a minimum.

Thermal Bridging: A thermal bridge is a building component within an assembly that has a relatively high thermal conductivity (low thermal resistance) compared to other components around it. Where the other components resist heat transfer, the thermal bridge provides the easiest path for heat to pass through the assembly. Thermal bridging can result in cooler interior surfaces and greater potential for condensation and comfort issues, in addition to decreasing the effective R-value of the assembly.

Thermal Insulation Legend:

Semi-rigid or rigid mineral fibre =

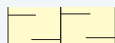

Mineral fibre batt =



Blown-in mineral fibre =



Common Locations of Thermal Bridges Through the Building Enclosure

The following is a list of key potential thermal bridging pathways throughout the building enclosure, as well as ways to minimize them.

- › **Framing members** - Wood framing in the building enclosure (i.e. studs, top and bottom plates, rim joists, etc.) should be insulated with continuous exterior insulation whenever possible to decrease the potential heat flow between the interior and exterior of a home.
- › **Cladding attachments and flashing** - Fasteners and continuous flashing that penetrate the insulation can be significant thermal bridges. Thermally efficient cladding attachments like stainless steel or fiberglass and lower-conductivity membrane flashings should be used where possible.
- › **Interfaces at windows and doors** - Thermal bridging around openings is often the most severe potential heat loss pathway. Over-insulating frames and setting them out in line with the insulation helps maintain a continuous thermal barrier
- › **Balconies and exposed floors** - The additional framing required and potential discontinuity of insulation should be avoided. Use externally supported balconies and avoid cantilevered projecting elements.
- › **Below-grade concrete to above-grade wall** - Where possible, exterior insulation should be used at the foundation and should be made continuous with the above-grade wall insulation.
- › **Below-grade concrete wall to slab** - Insulation should be carefully planned to achieve continuity around the concrete below-grade components. Slab edge thermal bridging must be avoided.
- › **Roof to wall interface** - Raised heel trusses allow for more insulation above the exterior wall areas.
- › **Building corners** - The additional structural elements at corners can't easily be avoided, especially in high-risk earthquake areas. Continuous exterior insulation should be used where possible.
- › **Services penetrations** - Plumbing and ductwork should not be located in exterior walls or within roof insulation as they interrupt insulation continuity. If they cannot be avoided, completely insulate around them to the full depth of the insulation. Wherever possible, use interior service walls and ceilings instead.



Infrared image of thermal bridging at studs, assembly interfaces, inside and outside building corners

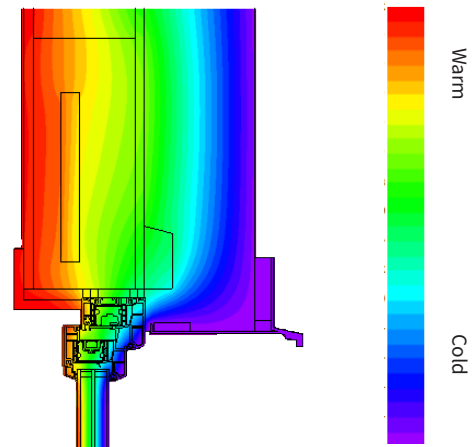

Modelled isotherm of window head with over insulated frame

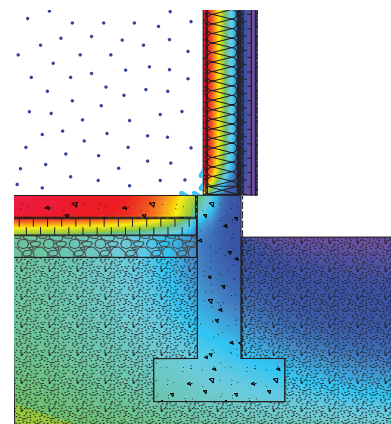

Excessive thermal bridging and ambient moisture can lead to condensation and thermal discomfort

Enclosure Durability

Critical Barriers

The term **critical barrier** refers to materials and components that together perform a control function within the building enclosure.

The **water-shedding surface (WSS)** refers to the outer surface of assemblies, interfaces, and details that deflect or drain the vast majority of the exterior water off the assembly. For wall assemblies, the WSS is the cladding; wood siding, vinyl, masonry veneer, or a variety of other materials. For windows, the WSS is a combination of the outer portion of the frame, exterior gaskets, glazing tape, or sealant, and the insulating glass unit. For roofs it is the shingles, metal roofing, or membrane.

The **water-resistive barrier (WRB)** is the surface farthest inward from the exterior that can accommodate moisture without incurring damage to interior finishes or materials within the assembly. It is not always easy to establish this barrier since some surfaces can accommodate small amounts of moisture for a limited time without damage, while larger quantities of water or longer exposure to moisture will lead to premature deterioration or migration of moisture further into the assembly. For many wall assemblies, the WRB is the sheathing membrane in combination with flashing and sealants at penetrations.

The **air barrier (AB)** controls the flow of air through the elements of the building enclosure, either inward or outward. Airflow is a significant variable with respect to space conditioning costs, condensation control and rain penetration control. For most window frames, the WRB (and air barrier) is likely the interior portion of frame members in combination with gaskets, glazing tape, or sealants that are not directly exposed to the exterior. Note that the glazing in windows is the WSS, the WRB and the air barrier. This illustrates the general point that specific materials within an assembly may perform several critical barrier functions.

Another critical barrier is the **vapour retarder** (often called a vapour barrier/VB) whose role is to control the outward diffusion of moisture through an enclosure. It is often comprised of sheet polyethylene located behind the interior finish, but other solutions are possible, such as vapour retarding paint or certain types of rigid foam insulation.

The primary function of **thermal insulation** is to limit conductive heat flow out of the building, a significant aspect of the thermal performance and energy efficiency of the building enclosure. The thermal resistance and vapour permeability of the materials that make up an assembly must be considered in order to control condensation.

The **building form and features**, while not strictly defined as a critical barrier, refers to the shape and configuration of the building and the protection from exposure to water these can provide for the building enclosure assemblies and elements.

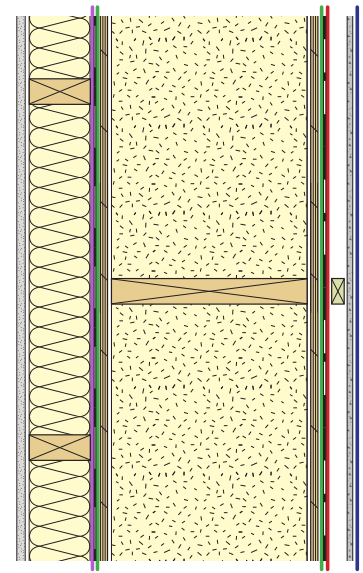

Interior-insulated (deep stud wall with service cavity)

- Water-shedding surface
- Water-resistive barrier
- Air barrier
- Thermal insulation
- Vapour retarder

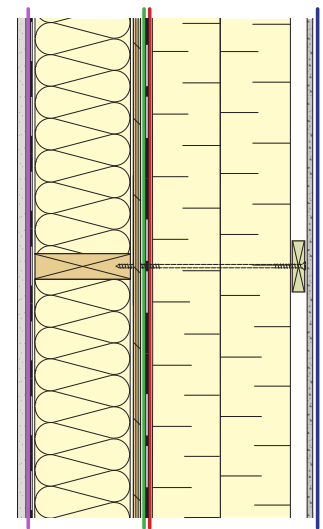

Split Insulated (interior and exterior insulated)

Rain/Water Penetration

The basic principles of rain and water penetration control have been well understood for many years. The application of those principles in real buildings has been less than ideal far too often. Controlling exposure to rain and water is a four step process:

- › **Deflection** - the use of components and features to limit exposure of assemblies to rain. This includes overhangs and flashings with drip edges.
- › **Drainage** - the use of drainage surfaces within cavities to redirect any water that enters the enclosure back to the exterior (rainscreen). The cavity space also stops capillary transport from the cladding to moisture-sensitive materials.
- › **Drying** - the use of features that speed the drying of wet materials.
- › **Durability** - the use of moisture tolerant assemblies and materials.

Airflow

Control of airflow is important to several aspects of building enclosure performance. For example:

- › Pressure moderation as a part of water penetration control is highly dependent on the existence of an effective air barrier.
- › An effective air barrier limits the amount of moisture that can be deposited within assemblies due to condensation.

For deep stud assemblies, or those without exterior insulation, an effective interior air barrier is crucial to reduce the amount of warm humid air that is allowed to enter the framing cavity and deposit moisture on the cold sheathing surface.

Condensation through interior air leakage is more severe than condensation through vapour flow and should be treated as a greater threat to enclosure durability.

Insulation Placement

Placing insulation outside of the sheathing (exterior insulation) results in the inside surface of the sheathing having a higher temperature, leading to decreased risk of condensation inside of the framing cavity. Assemblies without any exterior insulation are at greater risk of damage due to condensation.

With high-ratio thicknesses of exterior insulation, the sheathing will be above the interior dew point and condensation within the framing cavity will not be a problem. The resulting assembly is not at risk of vapour diffusion condensation or air leakage condensation and allows for a high degree of design flexibility and redundancy.

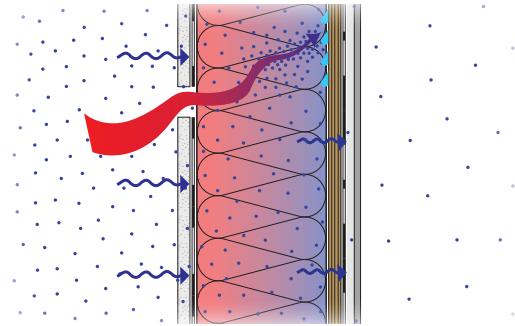

Condensation caused by interior air leakage

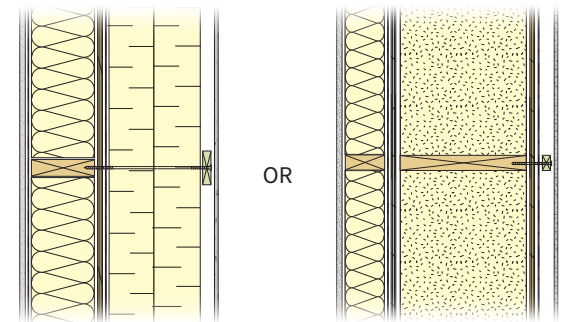

Split-insulated (interior and exterior insulation)

Interior-insulated (deep stud wall with service cavity)

Relative Humidity (RH): The ratio of the amount of water vapour in a volume of air to the maximum amount of water vapour it can hold at a given temperature. Often expressed in percentages. For example, fully saturated air is at 100% relative humidity.

Vapour Flow & Vapour Permeability of Building Materials

While water penetration is an important consideration, condensation moisture due to vapour diffusion (i.e., vapour flow) can also lead to damage if not effectively controlled. Condensation occurs on surfaces that are colder than the dew point temperature of the air they are exposed to. The variables that impact the potential for condensation include the temperature of surfaces, the air temperature, and the amount of vapour in the air (i.e., the dew point temperature; higher RH means higher dew point). Controlling condensation can be achieved by:

- › Minimizing vapour flow into/through assemblies by installing a vapour control layer such as a vapour retarder.
- › Reducing the amount of moisture in the indoor air.
- › Keeping surfaces warm, both interior surfaces and surfaces within building assemblies.
- › Controlling air movement into/through assemblies.

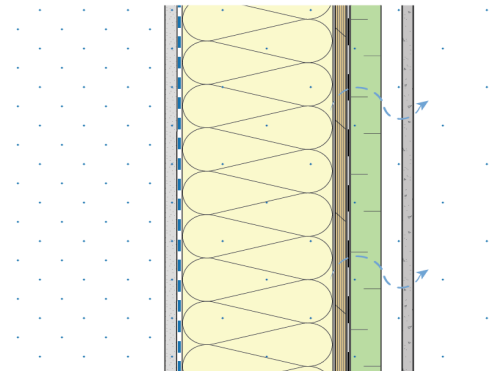

Permeable exterior insulation allowing for outward vapour flow

The predominant vapour flow through an insulated wood-frame assemblies in cool climates occurs outwards and should be controlled. There is increased flow in homes with high RH and colder exterior temperatures. Exterior insulation, sheathing, and the WRB can slow/stop the continued outward flow (diffusion) of vapour. Exterior walls should be designed to allow for the flow of vapour (for drying) in at least one direction from the plane of the moisture sensitive sheathing and stud cavity. For this reason using permeable exterior insulation is beneficial because it allows vapour to flow through to the exterior. The flow of vapor (drying) is a critical consideration, whether it be inward or outward, but when intending to dry to the outside, mineral fibre exterior insulation is an excellent part of the solution.

Insulation Ratios

When impermeable insulation is used, the ratio of insulation outboard of the sheathing to insulation in the stud cavity should be carefully considered so as to maintain the temperature of the sheathing at relatively safe levels (above dew point) to avoid condensation. Additionally, while not explicitly required by the codes, a relatively more permeable interior vapour barrier such as a smart vapour retarder or vapour retarder paint could be used to permit some amount of inward drying. In general, a vapour permeable exterior insulation in combination with an interior vapour barrier typically provides a lower risk wall assembly than does an assembly using impermeable exterior insulation. See BCBC/NBC 9.25.5 for code requirements.

Rainscreen Design

A rainscreen design is where a water-resistive barrier (WRB) is installed inboard of the cladding (WSS) as a secondary barrier to prevent water ingress, and a drainage gap is installed between the cladding and WRB to allow drainage of water which penetrates past the cladding and to increase the outward drying ability of the assembly. The use of a rainscreen design can greatly increase an assembly's durability. This approach is recommended for all wall assemblies, even in locations where not required by code.

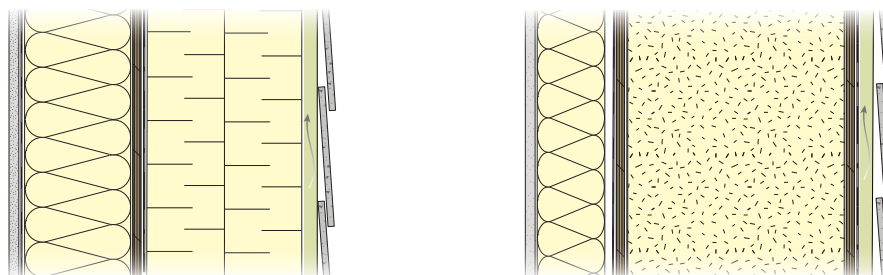

Wall assemblies utilizing rainscreen design result in greater water control and enhanced drying ability

Near Net Zero to Net Zero

Unlike near net zero buildings, net zero buildings have renewable energy generation and can produce at least the same amount of energy the building uses on an annual basis. This often means that they require energy production and storage systems to be installed on site. The most common energy generation solution for single family homes is a solar panel (i.e., photovoltaic (PV)) system located on the roof.

A photovoltaic system would require additional components and design such as:

- › Conduit and wiring to the rooftop PV array
- › Anchor points on the roof to support the PV array mounting racks
- › PV array (solar panels)
- › A method of servicing the PV array (safe rooftop access/anchors if required)
- › DC disconnect, solar inverter, charge controller, battery pack
- › Possibly a backup generator

A cost-effective way of building a near net zero building that could easily be turned into a net zero building (i.e., net zero ready) would be to install additional components during the initial construction process and to make allowances for the future installation of other more costly components. Components such as PV array mounting rack anchor points and conduit for the rooftop PV array wiring should be installed during initial construction to avoid costly electrical and roof re-work. Mechanical rooms should also be sized with enough room for the future installation of required electrical components that come with PV.

Required Amount of PV for Net Zero

The required amount of PV energy production for a net zero building is equal to the total energy consumption for the building in question, generally determined on an annual basis. The required area for the PV array depends on the location of the building (latitude), cloud cover and climate, the tilt of the PV panels (angle), the orientation of the panels, and the efficiency of the system. Depending on the size, orientation, and angle of the building's roof, the full PV array may be able to fit on it.

From the modelling performed for this guide, a near net zero, 2550 ft² (237 m²) two story house with a basement, located in Victoria (CZ4), with an enclosure-first approach, high-efficiency building equipment, and a south-facing single gable at a 6/12 slope, can produce 8.4kW (enough to power the full house) and only use 58.8% of the total roof area.

A useful online resource for calculating a PV array energy-generating capability is the [PVWatts Calculator](#) by NREL.

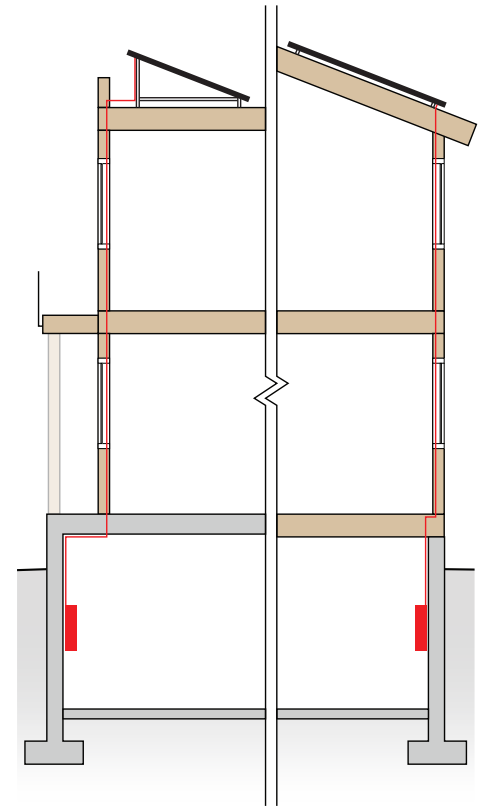

Building section illustrating components of a PV system and need for planning during the initial design phase

Photovoltaic (PV): A method for generating electric power by using solar cells to convert energy from the sun into a flow of electrons by the photovoltaic effect. Solar cells produce direct current electricity from sunlight which can be used to power equipment or to recharge batteries.

Photovoltaic Array (PV Array): Is the complete power-generating unit, consisting of any number of PV modules and panels.

Near Net Zero Above-Grade Wall Assemblies

Split-Insulated Stud Wall

This above-grade wall assembly consists of rigid or semi-rigid insulation placed on the exterior of a conventional above-grade insulated wood-frame wall assembly. High effective R-values are achieved by using continuous insulation outside of the structural framing and low-conductivity cladding attachments, in combination with insulation in the stud space. In most cases, cladding can be supported by strapping fastened with screws through the rigid insulation. It is also possible to use low-conductivity cladding attachment systems, such as metal or fiberglass clips or wood blocking. The exterior insulation product used in this arrangement should not be sensitive to moisture, as it will be exposed to periodic wetting. In cold climates, insulation placed on the exterior of the stud wall increases the temperature of the moisture-sensitive wood sheathing and framing and consequently often improves the durability of the assembly by reducing the risk of condensation and associated moisture damage.

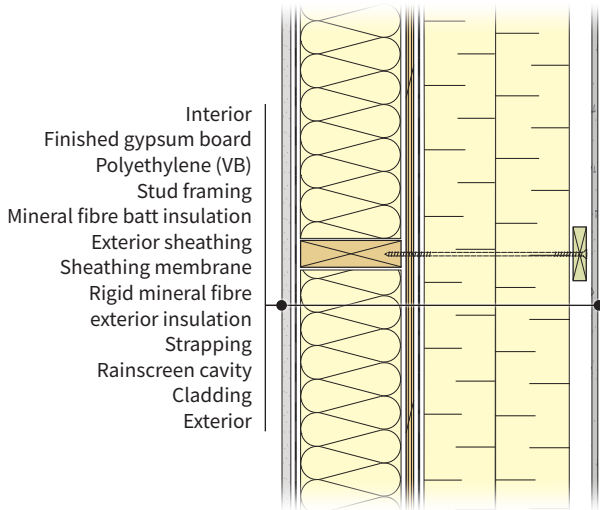

Plan view of split-insulated stud wall assembly

Air Barrier

This assembly can accommodate several air barrier strategies. However, often the most straightforward one to use is the exterior sheathing membrane. If the sheathing membrane is to form the air barrier, it must be taped and sealed to ensure continuity. Alternatively, a sealed sheathing approach can be used, or potentially an airtight drywall approach or airtight polyethylene, though ensuring continuity of the latter interior air barrier approaches can be arduous. Continuity of the air barrier at transitions and penetrations is critical to its performance.

Insulation

The stud space can be insulated using a variety of different insulation types, including batts (i.e., mineral wool or fiberglass) and blown-in mineral fibre insulation (i.e., fiberglass or mineral wool).

Various types of exterior insulation can potentially be used in split-insulation wall assemblies, including permeable insulations such as semi-rigid or rigid mineral wool, or semi-rigid fiberglass, and relatively impermeable foam plastic insulations. While each of these insulation materials can provide adequate thermal resistance, the permeability of the materials is of particular importance with respect to the drying capacity of the wall assembly.

Key Considerations

The method of cladding attachment is important to limit thermal bridging through the exterior insulation while adequately supporting the exterior cladding.

The vapour permeability of the sheathing membrane and exterior insulation should be carefully considered to avoid creating a risk of condensation within the assembly or reducing the ability of the assembly to dry in the event that incidental wetting occurs. See [Insulation Ratios](#) on Page 13 for more information and code reference.

Effective R-values of Split-Insulated Stud Walls (Exterior Insulation) $\text{ft}^2 \cdot \text{°F} \cdot \text{hr} / \text{Btu}$ ($\text{m}^2 \cdot \text{K} / \text{W}$)

	2x4 Framed Wall (R-12 Batts)		2x6 Framed Wall (R-19 Batts)		
	R-4 / inch	R-5 / inch	R-4 / inch	R-5 / inch	
4.0" (102mm)	27.3 (4.81)	31.3 (5.51)	32.2 (5.67)	32.2 (5.67)	4.0" (102mm)
4.5" (114mm)	29.3 (5.16)	33.8 (5.95)	34.2 (6.02)	38.7 (6.82)	4.5" (114mm)
5.0" (127mm)	31.3 (5.51)	36.3 (6.39)	36.2 (6.38)	41.2 (7.26)	5.0" (127mm)
5.5" (140mm)	33.3 (5.86)	38.8 (6.83)	38.2 (6.73)	43.7 (7.70)	5.5" (140mm)
6.0" (152mm)	35.3 (6.22)	41.3 (7.27)	40.2 (7.08)	46.2 (8.14)	6.0" (152mm)
6.5" (165mm)	37.3 (6.57)	43.8 (7.71)	42.2 (7.43)	48.7 (8.58)	6.5" (165mm)
7.0" (178mm)	39.3 (6.92)	46.3 (8.15)	44.2 (7.78)	51.2 (9.02)	7.0" (178mm)
7.5" (191mm)	41.3 (7.27)	48.8 (8.59)	46.2 (8.14)	53.7 (9.46)	7.5" (191mm)
8.0" (203mm)	43.3 (7.62)	51.3 (9.03)	48.2 (8.49)	56.2 (9.90)	8.0" (203mm)
9.0" (229mm)	47.3 (8.33)	56.3 (9.92)	52.2 (9.19)	61.2 (10.8)	9.0" (229mm)
10.0" (254mm)	51.3 (9.03)	61.3 (10.8)	56.2 (9.9)	66.2 (11.7)	10.0" (254mm)
11.0" (279mm)	55.3 (9.74)	66.3 (11.7)	60.2 (10.6)	71.2 (12.5)	11.0" (279mm)
12.0" (304mm)	59.3 (10.4)	71.3 (12.6)	64.2 (11.3)	76.2 (13.4)	12.0" (304mm)

A 23% framing factor is assumed, which is consistent with standard 16" o.c. stud framing practices in Part 9 construction. Thermal bridging through exterior insulation is not accounted for but may be worth considering depending on the attachment strategy used. Refer to the *Illustrated Guide - R22+ Effective Walls in Residential Construction in British Columbia* for more information.

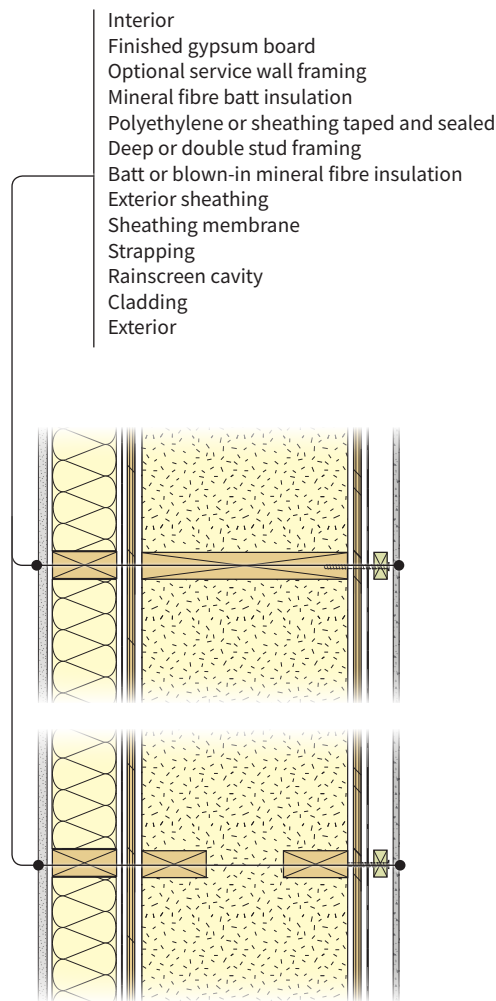

Plan view of interior-insulated deep stud/
double stud wall assembly

Key Considerations

The quality of the insulation installation is critical to limiting convective looping within the increased wall assembly depth. Such looping can reduce the effectiveness of the insulation and also contribute to moisture accumulation within the assembly.

Continuity of the air barrier and installation of an interior vapour barrier are fundamental to the performance of this assembly, as the slightly decreased exterior sheathing temperature (as compared to standard construction) increases the risk of condensation and related damage.

Interior-Insulated Deep Stud Wall

This above-grade wall assembly consists of a deeper stud cavity created using either deep studs or engineered wood I-joists, or double stud framing spaced apart, and an optional additional 2x4 service wall constructed on the interior to allow for running of electrical, plumbing, and HVAC services without penetrating the interior air barrier. High effective R-values are achieved by filling the increased cavity depth with either batt insulation or blown-in mineral fibre insulation. There is often no exterior insulation installed in this assembly, so cladding can be attached directly to the wall through vertical strapping and using standard rainscreen detailing. In cold climates, the additional depth of insulation installed on the interior side of the exterior sheathing can slightly decrease the sheathing temperature and consequently increase the risk of condensation. As a result, continuity of the air barrier and installation of an interior vapour barrier are critical to the performance of this assembly, as is the quality of the insulation installation to reduce airflow within the assembly (i.e., convective looping).

Air Barrier

The interior air barrier such as the polyethylene sheet or sealed sheathing should be detailed as the primary air barrier for this assembly. In addition to the interior air barrier, a secondary exterior air barrier such as the exterior vapour permeable sheathing membrane or sealed sheathing should be installed, to improve the overall assembly airtightness. This double air barrier approach reduces the risk of air movement and condensation within the wall cavity, which increases the durability and thermal performance of the assembly. Note that the interior air barrier transition at the floor line requires careful attention to achieve continuity.

Insulation

The stud space can be insulated using a variety of different insulation types, including batt (i.e., mineral wool or fiberglass) or blown-in mineral fibre insulation (i.e., fiberglass or mineral wool in dense-packed or dense-blown applications). With fibrous fill insulations, higher density blown products with integral binders can be used to prevent settlement within the deep wall cavity. The service wall stud space can either be insulated to increase the assembly R-value, or it can be left empty.

Effective R-values of Interior-Insulated Deep Stud Walls ft² ·°F·hr/Btu (m²·K/W)

Wall Framing	Uninsulated 2x4 Service Wall			2x4 R-12 Insulated Service Wall			Wall Framing
	R-3.4 / inch	R-4 / inch	R-5 / inch	R-3.4 / inch	R-4 / inch	R-5 / inch	
2x6 (5.5")	17.7 (3.12)	18.9 (3.33)	20.5 (3.61)	26. (4.58)	27.2 (4.79)	28.8 (5.07)	140mm
2x8 (7.25")	21.9 (3.86)	23.5 (4.14)	25.6 (4.51)	30.2 (5.32)	31.8 (5.6)	33.9 (5.98)	184mm
2x10 (9.25")	26.7 (4.70)	28.7 (5.05)	31.5 (5.55)	35.0 (6.17)	37.0 (6.52)	39.8 (7.00)	235mm
2x12 (11.25")	31.6 (5.57)	34.0 (5.99)	37.3 (6.57)	39.9 (7.02)	42.3 (7.45)	45.6 (8.04)	286mm
9.5" I-Joist	28.4 (5.00)	31.2 (5.49)	35.5 (6.25)	36.7 (6.46)	39.5 (6.96)	43.8 (7.72)	241mm I-Joist
11.9" I-Joist	35.4 (6.23)	39.2 (6.90)	44.9 (7.91)	43.7 (7.69)	47.5 (8.36)	53.2 (9.37)	302mm I-Joist
14" I-Joist	41.7 (7.34)	46.3 (8.15)	53.3 (9.39)	50.0 (8.80)	54.6 (9.62)	61.6 (10.84)	356mm I-Joist
16" I-Joist	47.6 (8.38)	53.0 (9.33)	61.1 (10.8)	55.9 (9.84)	61.3 (10.8)	69.4 (12.23)	406mm I-Joist

A 23% framing factor is assumed for the exterior wall assembly, which is consistent with standard 16" o.c. stud framing practices in Part 9 construction.
 16% framing factor is assumed for the service wall, which is consistent with advanced 24" o.c. stud framing practices in Part 9 construction.

Effective R-values of Interior-Insulated Double Stud Walls ft² ·°F·hr/Btu (m²·K/W)

Wall Framing	R-value of Insulation		
	R-3.4 / inch	R-4 / inch	R-5 / inch
0	21.3 (3.76)	23.4 (4.11)	26.2 (4.62)
.25" (6mm)	22.2 (3.91)	24.4 (4.29)	27.5 (4.84)
0.5" (13mm)	23.0 (4.06)	25.4 (4.46)	28.7 (5.06)
1.0" (25mm)	24.7 (4.36)	27.4 (4.82)	31.2 (5.50)
1.5" (38mm)	26.4 (4.65)	29.4 (5.17)	33.7 (5.94)
2.0" (51mm)	28.1 (4.95)	31.4 (5.52)	36.2 (6.38)
2.5" (64mm)	29.8 (5.25)	33.4 (5.87)	38.7 (6.82)
3.0" (76mm)	31.5 (5.55)	35.4 (6.23)	41.2 (7.26)
3.5" (89mm)	33.2 (5.85)	37.4 (6.58)	43.7 (7.70)
4.0" (102mm)	34.9 (6.15)	39.4 (6.93)	46.2 (8.14)
4.5" (114mm)	36.6 (6.45)	41.4 (7.28)	48.7 (8.59)
5.0" (127mm)	38.3 (6.75)	43.4 (7.63)	51.2 (9.03)

A 16% framing factor is assumed for the interior and exterior stud walls, which is consistent with advanced 24" o.c. stud framing practices in Part 9 construction.
 Add R-9.9 for walls with service cavity where R-12 batt insulation is installed (2x4 studs @ 24" o.c. assumed).

Near Net Zero Roof Assemblies

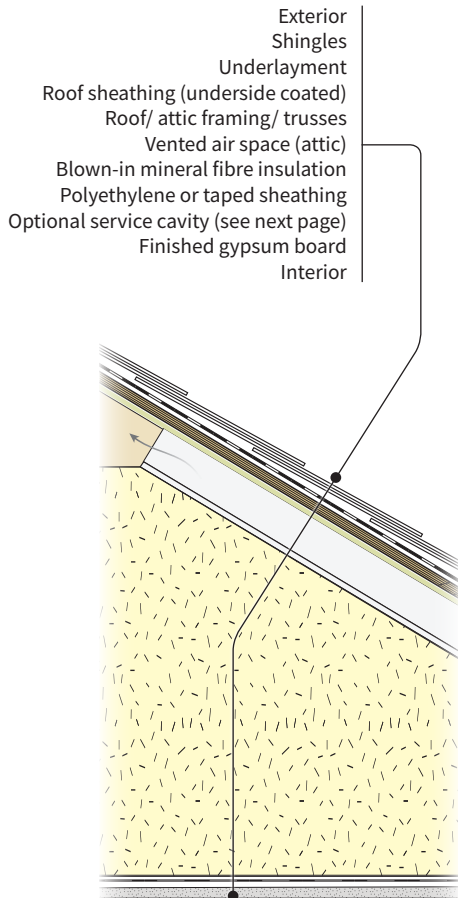

Section view of interior insulated vented attic roof

Key Considerations

Besides good roof detailing and watertightness, the performance of the assembly depends on a combination of adequate attic venting and airtightness of the ceiling.

In this assembly, the roof sheathing is at risk of condensation and fungal growth due to night sky radiation. An anti-fungal surface coating should be used to reduce this risk. For additional information on this, see the *Attic Ventilation and Moisture Research Study* published by BC Housing.

A service cavity at the ceiling will reduce the number of penetrations in the ceiling air barrier and improve its airtightness, and can also be a place to put additional insulation.

Interior-Insulated Vented Attic Roof

This sloped roof assembly consists of framed roof trusses with exterior sheathing at the top side and the ceiling finish below, with the addition of an optional service cavity constructed on the interior of the ceiling finish (see next page) to allow for running of electrical, plumbing, and HVAC services without penetrating the ceiling air barrier. Penetrations in the air barrier can be sealed from inside the attic if needed. High effective R-values are achieved by installing insulation above the ceiling and around the bottom chords of the roof trusses. The depth of the insulation can be adjusted to meet the roof R-value requirements, and is only limited by the depth of the roof trusses, with allowance for ventilation. This roof is often the most feasible option when R-values above R-80 are required. Continuity of the air barrier and installation of an interior vapour barrier are critical to the performance of this assembly. Note that vented roof assemblies may be at risk of condensation and resulting fungal growth due to night sky radiation at the underside of the roof sheathing, regardless of ceiling airtightness or ventilation levels (see [Key Considerations](#)).

Air Barrier

The interior polyethylene sheet or sheathing placed above the ceiling gypsum board (and ceiling service space if present) should be detailed as airtight to provide the air barrier for this assembly. This interior air barrier will prevent the flow of air into the attic space from the interior. A ceiling service cavity can be formed with framing lumber attached to the underside of the attic framing. This strategy is recommended where good ceiling airtightness is required to meet more stringent building airtightness targets. Note that the air barrier transition at the top of each interfacing wall requires careful attention to achieve continuity of the interior air barrier.

Insulation

The ceiling joist/bottom chord of the truss space can be insulated using a variety of different insulation types including batt (i.e., mineral wool or fibreglass) or blown-in mineral fibre insulation (i.e., fibreglass or mineral wool). With fibrous fill insulations, blown products with integral binders can be used to prevent settlement within the attic. Batts should be used at the roof perimeter, hatches and in any high wind areas. Attention should be paid during installation to not block the baffles, as their performance is crucial to the adequate ventilation of the attic space. At the roof perimeter, the roof slope may limit the thickness of the insulation. A raised heel truss should be used where possible in order to maintain insulation thickness.

Effective R-values of Interior-Insulated Vented Attic Roofs ft² · °F · hr/Btu (m² · K/W)

Insulation Depth	Without Service Cavity		With 1.5" Service Cavity	
	R-3.4 / inch	R-4 / inch	R-3.4 / inch	R-4 / inch
8" (203mm)	26.7 (4.70)	30.7 (5.41)	27.6 (4.86)	31.6 (5.57)
10" (254mm)	33.5 (5.90)	38.7 (6.82)	34.4 (6.06)	39.6 (6.97)
12" (304mm)	40.3 (7.10)	46.7 (8.22)	41.2 (7.26)	47.6 (8.38)
14" (356mm)	47.1 (8.29)	54.7 (9.63)	48.0 (8.45)	55.6 (9.79)
16" (406mm)	53.9 (9.49)	62.4 (11.0)	54.8 (9.65)	63.6 (11.2)
18" (457mm)	60.7 (10.7)	70.7 (12.5)	61.6 (10.8)	71.6 (12.6)
20" (508mm)	67.5 (11.9)	78.7 (13.9)	68.4 (12.0)	79.6 (14.0)
24" (610mm)	81.1 (14.3)	94.7 (16.7)	82.0 (14.4)	95.6 (16.8)
30" (762mm)	102 (18.0)	119 (21.0)	102 (18.0)	102 (18.0)

A 10% framing factor is assumed for the lower 3.5" of insulation based on raised heel truss framing at 16" o.c. Components above the vented attic space are not included in the effective R-value calculation.

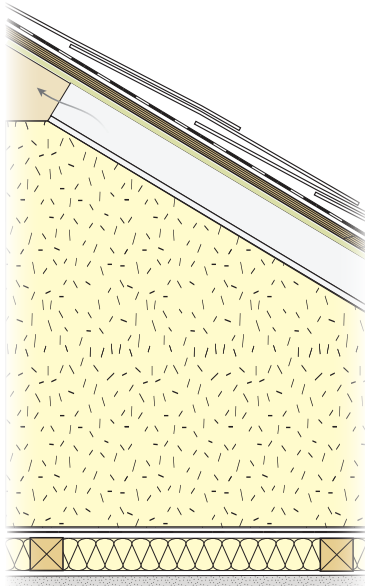

Interior-insulated vented attic roof with insulated service cavity

For assemblies with many ceiling penetrations, such as for electrical services, it will be difficult to achieve a continuous interior air barrier. To avoid these penetrations, an interior service cavity beneath the ceiling air barrier can be used to run services. The interior service cavity can either be insulated to increase the assembly R-value, or it can be left empty.

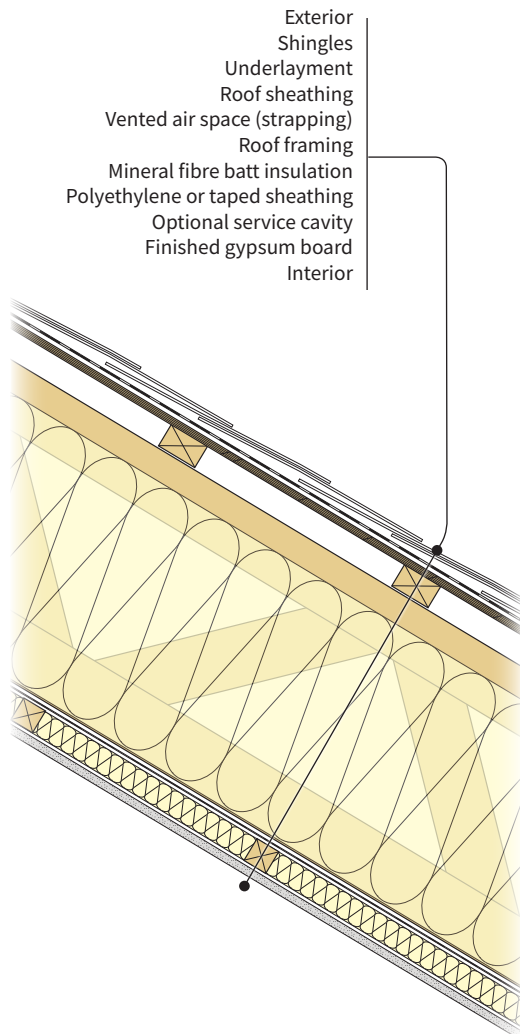

Section view of interior insulated vented vaulted roof

Key Considerations

Besides good roof detailing and watertightness, the performance of the assembly depends on a combination of adequate roof venting and airtightness of the ceiling.

A service cavity at the ceiling will reduce the number of penetrations in the ceiling air barrier and improve its airtightness.

Interior-Insulated Vented Vaulted Roof

This sloped roof assembly consists of roof joist framing with exterior sheathing at the top side and the ceiling finish below. A service cavity can be constructed on the interior between the ceiling finish and sheathing/polyethylene to allow for running of electrical, plumbing, and HVAC services without penetrating the ceiling air barrier. Penetrations in the air barrier are sealed at the interior side of sheathing/polyethylene. High effective R-values are achieved by installing insulation in the joist space. The depth of the insulation is limited by the depth of the roof joists, with allowance for ventilation. Engineered trusses can be used to create a deep joist space. Continuity of the air barrier and allowance for adequate ventilation at the top side of the insulation are critical to the performance of this assembly.

Air Barrier

The interior polyethylene sheet or sheathing above the ceiling service cavity should be detailed as airtight to provide the air barrier for this assembly. This interior air barrier will prevent the flow of air into the roof joist space from the interior. The ceiling service cavity can be formed with dimensional framing lumber. Note that the air barrier transition at the top of each interfacing wall requires careful attention to achieve continuity of the interior air barrier.

Insulation

The roof joist / truss space can be insulated using a variety of different insulation types including batt (i.e., mineral wool or fiberglass) or blown-in mineral fibre insulation (i.e., mineral wool or fiberglass).

The insulation should be held back from the interior surface of the roof sheathing to allow for adequate venting. The BCBC requires 2.5" (64mm) of vent space, measured from the interior surface of the sheathing to the top surface of the insulation. Cross strapping (purlins) above the joists provide for ventilation pathways across the top of the insulation in all directions.

See the *Illustrated Guide, R30+ Effective Vaulted & Flat Roofs in Residential Construction in British Columbia* published by BC Housing.

Effective R-values of Interior-Insulated Vented Vaulted Roofs $\text{ft}^2 \cdot \text{°F} \cdot \text{hr} / \text{Btu}$ ($\text{m}^2 \cdot \text{K} / \text{W}$)

Joist Framing	Without Service Cavity		With 1.5" Service Cavity		Joist Framing
	R-3.4 / inch	R-4 / inch	R-3.4 / inch	R-4 / inch	
2x8 (7.25")	18.6 (3.28)	20.6 (3.63)	19.5 (3.43)	21.5 (3.79)	184mm
2x10 (9.25")	24.1 (4.24)	26.8 (4.72)	25.0 (4.40)	27.7 (4.88)	235mm
2x12 (11.25")	29.6 (5.21)	33.0 (5.81)	30.5 (5.37)	33.9 (5.97)	286mm
9.5" I-Joist	25.9 (4.56)	29.0 (5.12)	25.9 (4.56)	29.0 (5.12)	241mm
11.9" I-Joist	32.7 (5.76)	36.8 (6.48)	32.7 (5.76)	36.8 (6.48)	302mm
14" I-Joist	38.8 (6.83)	43.7 (7.7)	38.8 (6.83)	43.7 (7.7)	356mm
16" I-Joist	44.6 (7.85)	50.2 (8.84)	44.6 (7.85)	50.2 (8.84)	406mm
20" Truss	56.2 (9.9)	63.3 (11.1)	56.2 (9.9)	63.3 (11.1)	508mm
24" Truss	67.7 (11.9)	76.3 (13.4)	67.7 (13.4)	76.3 (13.4)	610mm

Framing factor is assumed to be 13% for standard joist framing at 16" o.c. and 10% for I-joists and truss framing at 16" o.c. Components above the vented roof space are not included in the effective R-value calculation. Insulation depth assumes at least 1" vent space in joist cavity (more is often required and can be achieved with cross strapping). The BCBC requires 2.5" of vent space in every joist cavity, measured from the interior surface of the sheathing to the top surface of the insulation.

Split-Insulated Low-Slope Roof

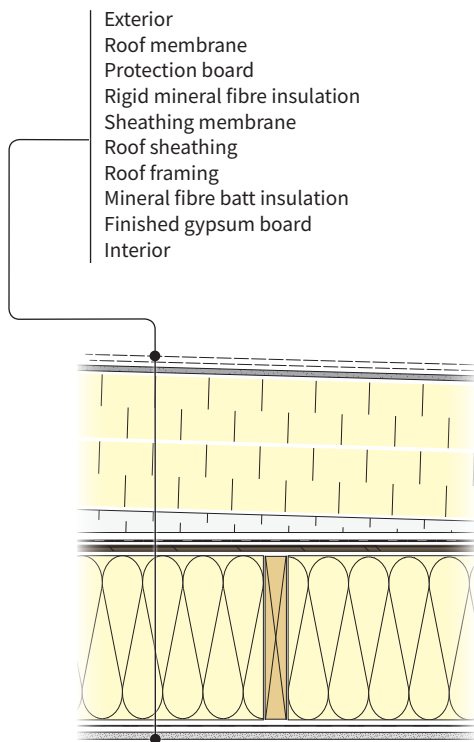

Section view of split-insulated low slope roof

Key Considerations

The split-insulated roof assembly must be carefully designed to ensure the interior insulation does not result in condensation risk at the roof sheathing.

Where possible, split-insulated roofs should be designed using hygrothermal design software that considers the climate and interior conditions that the assembly will be exposed to.

Multiple insulation layers should be offset, such that board edges of different layers do not align one atop one another. This ensures there is a continuous uniform layer of insulation. This roof relies on the secure attachment of the rigid insulation for the adequate wind uplift resistance of all assembly components. Insulation attachment methods include roofing adhesives and/or pin fasteners through the insulation to the roof framing. Care must be taken when using mechanical attachment methods. The recommend approach is the use of adhesives with rigid mineral wool.

This flat roof assembly consists of rigid insulation placed on the exterior of insulated roof framing. High effective R-values are achieved by using continuous insulation outside of the structural framing in combination with thermally efficient attachments, and supplemented by insulation in the framing cavity. In most cases the roofing substrate (such as protection board) can be fastened directly through the rigid insulation into the roof sheathing and framed assembly. The waterproof roofing membrane above the insulation controls all exterior moisture. The sheathing membrane over the roof sheathing is used as the air barrier and vapour retarder. This split-insulated approach must be carefully designed to ensure the interior insulation does not result in condensation risk at the roof sheathing.

Air Barrier

The most straightforward air barrier approach for this assembly is to use the self-adhered sheathing membrane over the roof sheathing. Continuity of the air barrier at transitions and penetrations is critical to its performance. This membrane may also be used as temporary roofing during construction, and should therefore also be detailed as watertight.

Insulation

Various types of rigid insulation can potentially be used above the sheathing in this assembly, including rigid mineral fibre, extruded polystyrene (XPS), expanded polystyrene (EPS), and polyisocyanurate (polyiso). Insulation placed at the interior can be batt (i.e., mineral wool or fibreglass), or blown-in mineral fibre insulation (i.e., mineral wool or fibreglass). The ratio of interior-to-exterior insulation R-value in this assembly must be carefully considered to avoid risking condensation at the underside of the roof sheathing. Split-insulated roofs should be designed using hygrothermal design software or calculations that consider the climate zone and interior conditions that the assembly will be exposed to. As a starting point, the assembly should have at least 65% of the total nominal insulation R-value placed at the exterior of the roof sheathing.

Interior vapour control is also important in this assembly in order to prevent excessive ambient moisture from reaching the sheathing, without trapping moisture that may enter the assembly. A relatively more permeable interior vapour barrier such as a smart vapour retarder or vapour retarder paint could be used. Depending on the insulation ratio and results of hygrothermal calculations, the assembly may not need interior vapour control.

Effective R-values of Split-Insulated Low-Slope Roofs ft²·°F·hr/Btu (m²·K/W)

Continuous Exterior Insulation R-value	2x8 (7 1/4") Filled Framing		2x10 (9 1/4") Filled Framing	
	R-3.4 / inch	R-4 / inch	R-3.4 / inch	R-4 / inch
	R-24	45.3 (7.98)	47.7 (8.40)	50.8 (8.95)
R-28	49.3 (8.68)	51.7 (9.10)	54.8 (9.65)	57.8 (10.2)
R-32	53.3 (9.39)	55.7 (9.81)	58.8 (10.4)	61.8 (10.9)
R-40	61.3 (10.8)	55.7 (9.81)	58.8 (10.4)	61.8 (10.9)
R-48	69.3 (12.2)	71.7 (12.6)	74.8 (13.2)	77.8 (13.7)
R-56	77.3 (13.6)*	79.7 (14.0)	82.8 (14.6)	85.8 (15.1)
R-64	85.3 (15.0)*	87.7 (15.4)*	90.8 (15.9)*	93.8 (16.5)

A 13% framing factor is assumed which is consistent with standard 16" o.c. joist framing practices in Part 9 construction.

Near Net Zero Below-Grade Assemblies

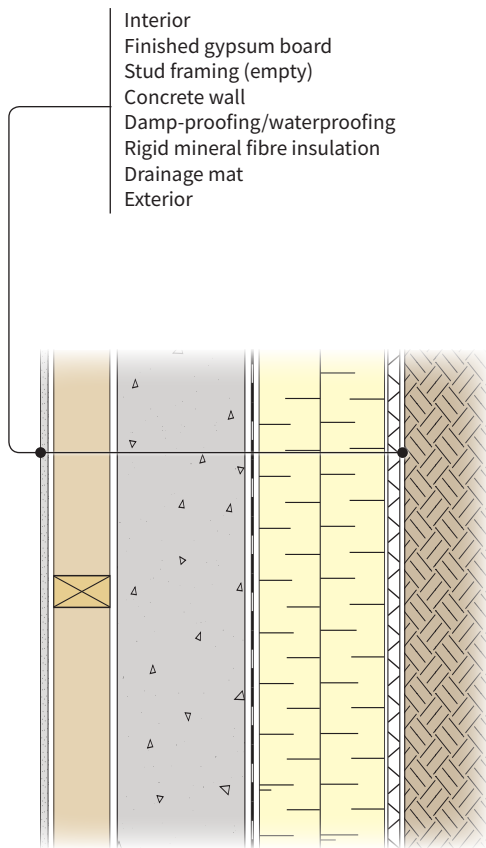

Plan view of exterior-insulated foundation wall

Key Considerations

Drainage to deflect water away from the foundation wall is important to the long-term performance of this wall assembly with respect to water penetration.

Detailing of the wall to ensure continuity of the water-resistive barrier, air barrier, vapour barrier, and insulation at the below-grade to above-grade wall transition is important to the overall performance.

The exterior of foundation walls can be difficult and expensive to access post-construction. It is prudent to design these assemblies conservatively with respect to water penetration and to use durable materials.

Exterior-Insulated Foundation Wall

This below-grade wall assembly consists of rigid mineral fibre insulation placed on the exterior of the concrete foundation wall. A wood stud wall is often constructed on the interior of the concrete wall to provide room for electrical and plumbing services. High effective R-values are achieved by using continuous insulation outside of the concrete structure. The insulation product used in this arrangement should be highly moisture tolerant and suitable for below-grade applications. In cold climates, insulation placed on the exterior of the wall increases the temperature of the concrete and consequently often reduces the risk of condensation and associated damage to moisture-sensitive interior wall components and finishes. Drainage is provided at the exterior of the insulation to eliminate hydrostatic pressure on the wall assembly and reduce the risk of water ingress.

Air Barrier

The concrete wall with applied damp/ waterproofing is the most airtight element in this assembly and is usually the most straightforward to make continuous with adjacent building enclosure assemblies such as the concrete floor slab (or air barrier below the slab) and above-grade walls.

Insulation

Various types of insulation can be used, including rigid mineral fibre, extruded polystyrene, and high density expanded polystyrene. It is important that the selected insulation product is moisture tolerant as it can potentially be exposed to significant dampness and possible wetting in this below-grade application. The use of exterior rigid mineral fibre at the exterior of the concrete foundation wall also helps the wall assembly with drainage.

The exterior insulation in this assembly will maintain the concrete structure at closer to indoor temperatures, consequently typically reducing the risk of condensation and associated damage.

If more than 50% of the insulation is located outside of the concrete structure, the interior stud wall can be filled with insulation to increase the effective R-value of the assembly.

Effective R-values of Exterior-Insulated Foundation Walls $\text{ft}^2 \cdot \text{°F} \cdot \text{hr} / \text{Btu}$ ($\text{m}^2 \cdot \text{K} / \text{W}$)

	R-value of Insulation		
	R-4 / inch	R-5 / inch	R-6 / inch
2.0" (51mm)	10.6 (1.87)	12.6 (2.22)	14.6 (2.57)
3.0" (76mm)	14.6 (2.57)	17.6 (3.10)	20.6 (3.63)
4.0" (102mm)	18.6 (3.28)	22.6 (3.98)	26.6 (4.68)
5.0" (127mm)	22.6 (3.98)	27.6 (4.86)	32.6 (5.74)
6.0" (152mm)	26.6 (4.68)	32.6 (5.74)	38.6 (6.80)
7.0" (178mm)	30.6 (5.39)	37.6 (6.62)	44.6 (7.85)
8.0" (203mm)	34.6 (6.09)	42.6 (7.50)	50.6 (8.91)
9.0" (229mm)	38.6 (6.80)	47.6 (8.38)	56.6 (9.97)
10.0" (254mm)	42.6 (7.50)	52.6 (9.26)	62.6 (11.0)
11.0" (279mm)	46.6 (8.21)	57.6 (10.1)	68.6 (12.1)
12.0" (304mm)	50.6 (8.91)	62.6 (11.0)	74.6 (13.1)

Thickness of Exterior Insulation

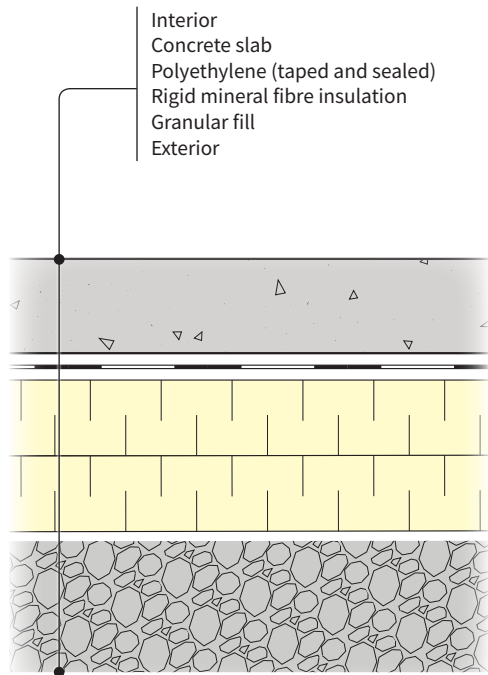

Section view of exterior-insulated slab

Key Considerations

The exposed insulation and air barrier membrane are susceptible to damage during construction and should be carefully monitored and protected until they can be permanently covered.

A major factor in the long-term performance of the floor assembly for moisture penetration control is the use of a properly installed and well-maintained below-grade drainage system. When using rigid mineral fibre it is crucial that the assembly has an effective drainage system and that the insulation does not get wet.

Soil gas/ radon protection may be required by the BCBC depending on the location of the building. The use of the polyethylene and an additional layer of gravel below the insulation layer will create a sub-slab depressurization system and meet the BCBC requirements.

Exterior-Insulated Floor Slab

This below-grade slab assembly consists of rigid insulation placed beneath the polyethylene air barrier and concrete slab. High effective R-values are achieved by using continuous insulation outside of the concrete slab. The insulation product used in this arrangement should be highly moisture tolerant and suitable for below-grade applications. In cold climates, insulation placed on the exterior of the slab increases the temperature of the concrete and consequently often reduces the risk of condensation and associated damage to moisture-sensitive interior floor components and finishes. A capillary break is provided between the slab assembly and the ground by a layer of coarse, clean granular fill to eliminate hydrostatic pressure on the floor assembly and reduce the risk of water ingress. The polyethylene also functions as a capillary break in this assembly.

Air Barrier and Soil Gas/ Radon Control

The polyethylene sheet bonded to the cast concrete slab is the air barrier in this assembly and is usually the most straightforward to make continuous with adjacent building enclosure assemblies such as the concrete foundation wall. The polyethylene sheet should be taped and sealed at all laps and penetrations. Besides providing a robust air barrier, the polyethylene functions as the vapour barrier, and as part of the soil gas mitigation system where required. A high-density polyethylene (HDPE) sheet is recommended, as it should be robust enough to withstand exposure to foot traffic and abrasion (i.e., remain continuous) prior to and after the concrete slab installation.

Insulation

Various types of insulation can be used, including rigid mineral fibre, extruded polystyrene, and high-density expanded polystyrene. It is important that the selected insulation product is moisture tolerant, as it will be exposed to dampness and possible wetting in this below-grade application.

The exterior insulation in this assembly will maintain the concrete slab at closer-to-indoor temperatures, enhancing comfort, typically reducing the risk of condensation and associated damage, and allowing for more durable installation of a wider range of floor finishes.

Although not always required by code, full insulation coverage below floor slabs is recommended. Compared to perimeter-insulated slabs, completely insulated slabs perform better in energy efficiency, moisture, and condensation control. They also result in a more occupant friendly, and thermally comfortable below-grade space.

Effective R-values of Exterior-Insulated Floor Slabs $\text{ft}^2 \cdot \text{°F} \cdot \text{hr} / \text{Btu}$ ($\text{m}^2 \cdot \text{K} / \text{W}$)

	R-Value of Insulation		
	R-4 / inch	R-5 / inch	R-6 / inch
2.0" (51mm)	9.1 (1.60)	11.1 (1.95)	13.1 (2.30)
3.0" (76mm)	13.1 (2.31)	16.1 (2.84)	19.1 (3.36)
4.0" (102mm)	17.1 (3.01)	21.1 (3.72)	25.1 (4.42)
5.0" (127mm)	21.1 (3.72)	26.1 (4.60)	31.1 (5.48)
6.0" (152mm)	25.1 (4.42)	31.1 (5.48)	37.1 (6.53)
7.0" (178mm)	29.1 (5.12)	36.1 (6.36)	43.1 (7.60)
8.0" (203mm)	33.1 (5.83)	41.1 (7.23)	49.1 (8.65)
9.0" (229mm)	37.1 (6.53)	46.1 (8.12)	55.1 (9.70)
10.0" (254mm)	41.1 (7.23)	51.1 (8.90)	61.1 (10.8)
11.0" (279mm)	45.1 (7.94)	56.1 (9.88)	67.1 (11.8)
12.0" (304mm)	49.1 (8.65)	61.1 (10.8)	73.1 (12.9)

Example Near Net Zero Building Details

The following pages contain 5 example interface details for highly-insulated above-grade and below-grade assemblies. Each detail highlights in green the air barrier components used to achieve continuity of the air barrier across the transitions shown. These details also illustrate the importance of continuity of the various other critical barriers, including thermal insulation. While all building interfaces and penetrations should be detailed prior to construction these examples provide a starting point for overall detailing. Refer the guides listed in the [Additional Resources](#) for further information on building detailing and air barrier continuity.

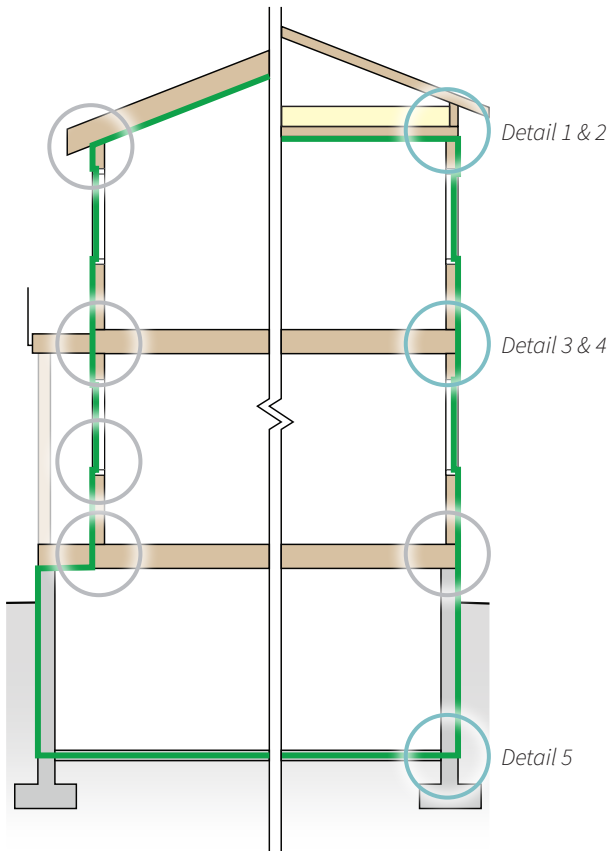

- Detail 1: Interior-Insulated Attic Roof to Split-Insulated Wall 31
- Detail 2: Interior-Insulated Attic Roof to Interior-Insulated Deep Stud Wall 32
- Detail 3: Split-Insulated Wall to Exterior-Insulated Foundation Wall. 33
- Detail 4: Interior-Insulated Deep Stud Wall to Exterior/Split-Insulated Foundation Wall 34
- Detail 5: Exterior-Insulated Foundation Wall to Exterior-Insulated Floor Slab 35

Building section with typical detail locations requiring careful design and planning for insulation and air barrier continuity, and the locations of the five example details.

Important Detailing Considerations

Air Barrier Continuity

When devising the details and planning for air barrier continuity, and indeed continuity of all critical barriers, it is important to consider the following key constructibility and sequencing issues:

- › Use approaches that allow for common construction sequencing (e.g., formwork, concrete, framing, cladding etc.), and separate the air barrier transition work from the various other phases such as framing wherever possible.

- › Use “inspectable” approaches that don’t rely on blind seals behind framing members or finishes. Direct-applied membranes, tapes and sealants are easier to inspect and make airtight compared to concealed gaskets or spray foam applications.
- › Keep it details as simple as possible, using construction materials and techniques that are accessible and straightforward. Where possible, keep the building shape simple to minimize intersections, especially roof-to-wall interfaces.

Careful consideration and attention to detail is required to ensure a continuous air barrier between assemblies, penetrations, and building components. This is important because each is part of the air barrier system, which should provide a durable and continuous air barrier across the entire building enclosure. Common deficiencies and challenging areas for exterior air barrier installation can occur at all areas of the air barrier system. The integrity of the air barrier relies upon the quality and completeness of the installation work. During construction, ensure the detailing work is reviewed and tracked by a dedicated site attendant. Tracking issues and potential deficiencies is one of the best ways to improve overall building airtightness and correct detailing. Some common air barrier challenges and likely deficiency locations include:

- › Structural and service wall penetrations using sealant and membranes
- › Wrinkled/fish-mouth/incomplete membrane laps
- › Roof-to-wall and other interfaces where various transition materials are used
- › Roof/ceiling penetrations
- › Window membrane and perimeter sealing
- › Interior ceiling penetrations and partition walls at an interior air barrier
- › Above-grade to below-grade transitions
- › Complex building forms and enclosure shapes such as fin walls and projections

Flanged vs. Non-flanged Windows

Flanged windows, where the window frame is attached using a dedicated perimeter nailing flange, are common place in current modern construction, but may be less desirable in high-performance walls. Since the flange must always be at or near the wall sheathing for attachment, the window placement in the opening is constricted and may not align well with the insulation. It also does not allow for over-insulation of the frame, a practice that provides significant benefit to the overall thermal performance of the enclosure. High-performance non-flanged windows are likely better suited to high-performance walls, since their attachment method using clips allows for greater flexibility in positioning in the opening. It is better practice to align the window with the middle of the insulation (in section) to allow better thermal continuity, and over insulate the perimeter frame.

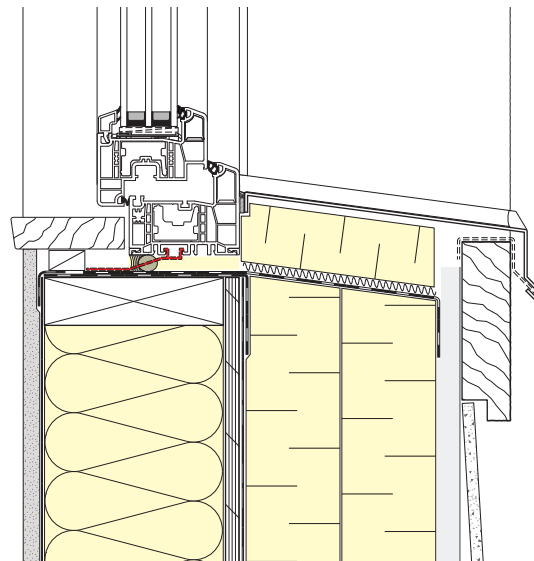

Non-flanged windows allow for better placement of the window to align with the wall insulation and allow for over-insulation

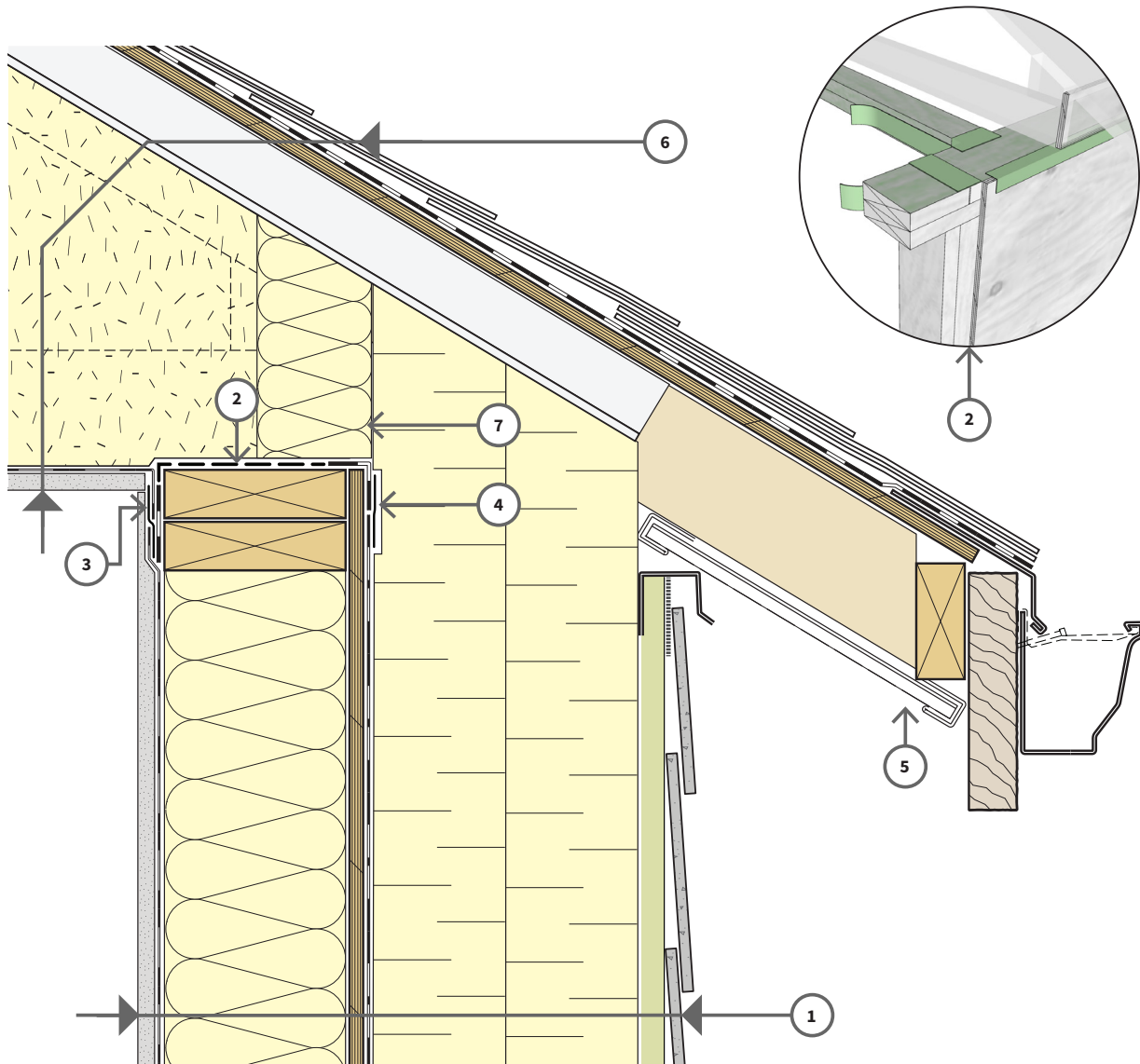

LEGEND

- | | |
|---|--|
| <p>1. Wall assembly</p> <ul style="list-style-type: none"> Cladding (fibre cement siding) 3/4" (19 mm) wood furring (p.t.) 8" (203 mm) rigid mineral fibre insulation Self-adhered vapour-permeable sheathing membrane AB Sheathing Wood framing 2x6 (38x140 mm) Mineral fibre batt insulation Interior vapour control membrane AB Gypsum board <p>2. High-performance sheathing tape over top plate joints, outside perimeter, and inside faces AB</p> <p>3. Ceiling vapour control membrane taped to top plate tape AB</p> <p>4. Sheathing membrane taped to top plate tape AB</p> | <p>5. Perforated soffit panel</p> <p>6. Roof assembly</p> <ul style="list-style-type: none"> Roofing shingles Waterproof roof membrane for eave protection (extends min. 12" (300 mm) beyond int. face of wall) Roof sheathing Wood roof framing at attic space Mineral fibre fill insulation Interior vapour control membrane AB Gypsum board <p>7. Fill Insulation retainer (batt Insulation)</p> |
|---|--|

WATER-SHEDDING ROOF - WALL | DETAIL 1

INTERIOR-INSULATED ATTIC ROOF TO SPLIT-INSULATED WALL

FOR ILLUSTRATION PURPOSES ONLY - NOT FOR CONSTRUCTION

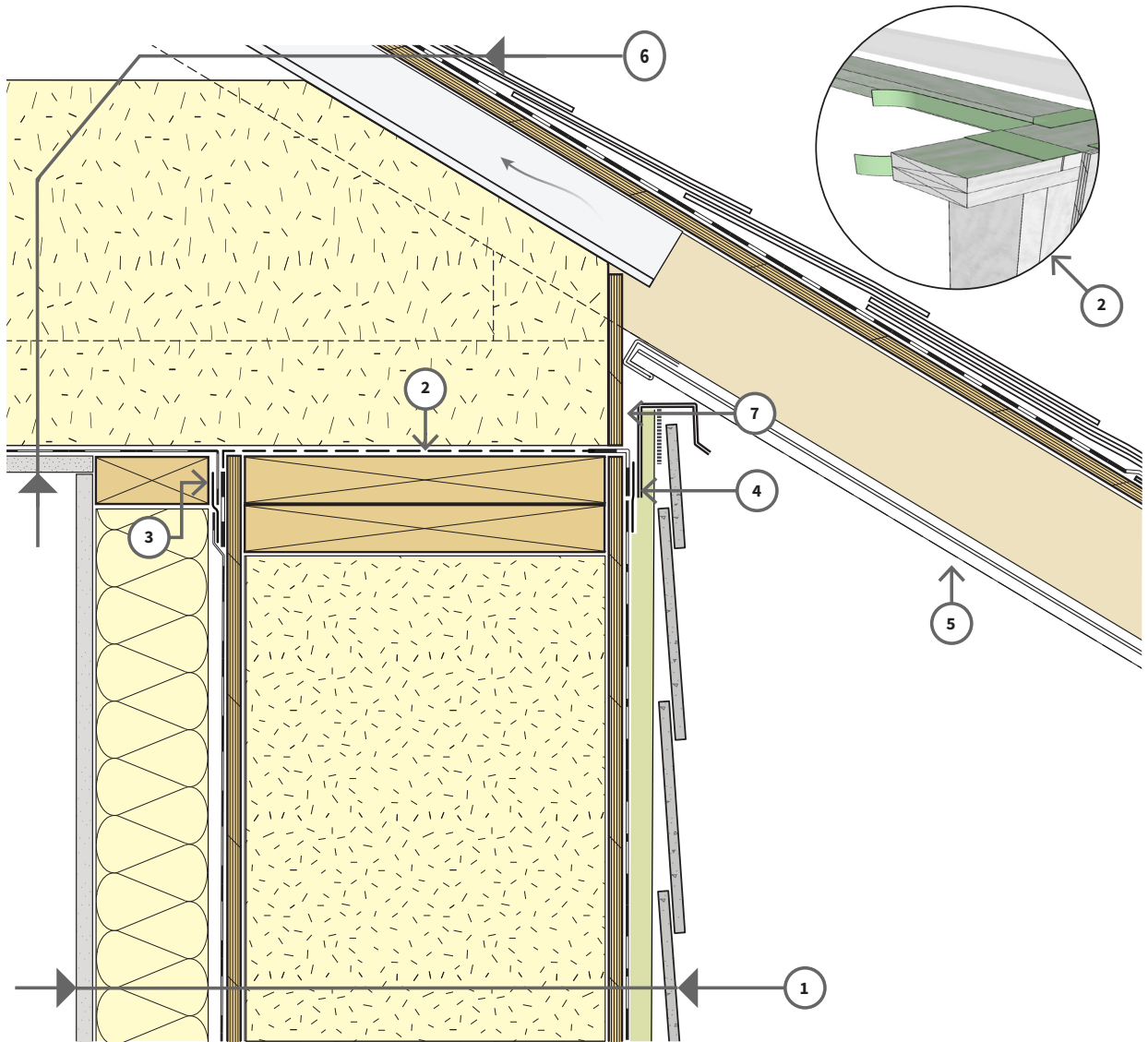

LEGEND

- | | |
|---|---|
| <p>1. Wall assembly</p> <ul style="list-style-type: none"> Cladding (fibre cement siding) 3/4" (19 mm) wood furring (p.t.) Self-adhered vapour-permeable sheathing membrane AB Sheathing Wood framing 2x12 (38x286 mm) Mineral fibre fill insulation Sheathing taped and sealed Interior vapour control membrane AB Wood framing 2x4 (38x89 mm) Mineral fibre batt insulation (service cavity) Gypsum board <p>2. High-performance sheathing tape over top plate joints, outside perimeter, and inside faces AB</p> <p>3. Ceiling vapour control membrane taped to top plate tape AB</p> | <p>4. Sheathing membrane taped to top plate tape AB</p> <p>5. Perforated soffit panel</p> <p>6. Roof assembly</p> <ul style="list-style-type: none"> Roofing shingles Waterproof roof membrane for eave protection (extends min. 12" (300 mm) beyond int. face of wall) Roof sheathing Wood roof framing at attic space Mineral fibre fill insulation Interior vapour control membrane AB Gypsum board <p>7. Insulation retainer sheathing</p> |
|---|---|

WATER-SHEDDING ROOF - WALL | DETAIL 2

INTERIOR-INSULATED ATTIC ROOF TO INTERIOR-INSULATED DEEP STUD WALL

FOR ILLUSTRATION PURPOSES ONLY - NOT FOR CONSTRUCTION

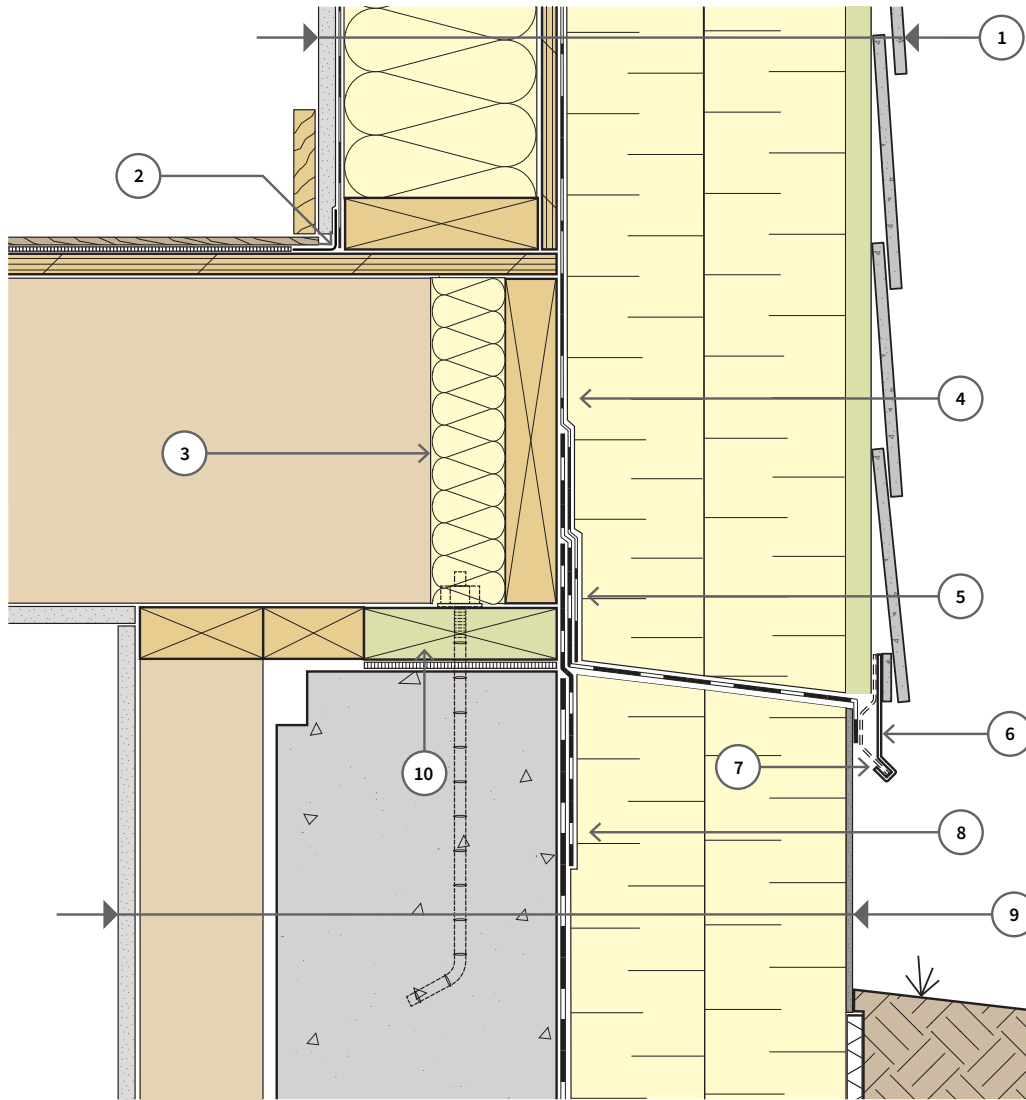

LEGEND

1. Wall assembly
 - Cladding (fibre cement siding)
 - 3/4" (19 mm) wood furring (p.t.)
 - 8" (203 mm) rigid mineral fibre insulation
 - Self-adhered vapour-permeable sheathing membrane AB
 - Sheathing
 - Wood framing 2x6 (38x140 mm)
 - Mineral fibre batt insulation
 - Interior vapour control membrane AB
 - Gypsum board
2. Tape between interior membrane and floor sheathing AB
3. Batt insulation
4. Self-adhered membrane lapped onto flashing membrane AB
5. Compatible self-adhered flashing membrane over transition strip, rigid mineral fibre and cement board AB
6. Pre-finished base of wall flashing
7. Continuous perforated retention/flashing clip
8. Self-adhered transition strip membrane AB
9. Wall assembly
 - Cement board (or parge coat) and drain mat
 - 8" (203 mm) rigid mineral fibre insulation
 - Damp-proofing
 - Concrete foundation wall AB
 - 3/8" (10 mm) air space
 - Wood framing
 - Gypsum board
10. Pressure-treated sill plate on sill gasket

WALL - FOUNDATION WALL | **DETAIL 3**

SPLIT-INSULATED WALL TO EXTERIOR-INSULATED FOUNDATION WALL

FOR ILLUSTRATION PURPOSES ONLY - NOT FOR CONSTRUCTION

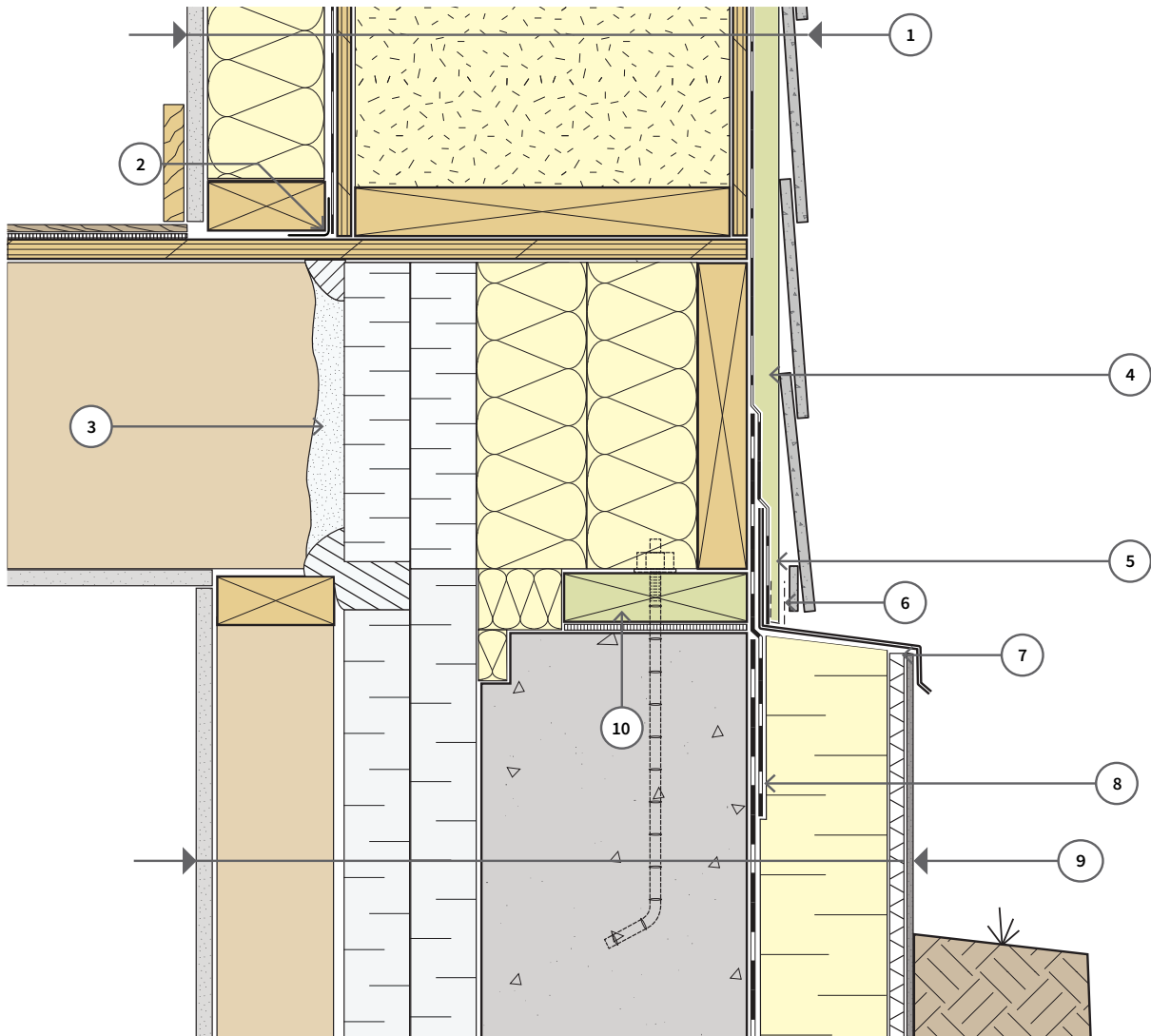

LEGEND

- | | |
|---|--|
| <p>1. Wall assembly</p> <ul style="list-style-type: none"> Cladding (fibre cement siding) 3/4" (19 mm) wood furring (p.t.) Self-adhered vapour-permeable sheathing membrane AB Sheathing Wood framing 2x12 (38x286 mm) Mineral fibre fill insulation Sheathing (optional) Interior vapour control membrane AB Wood framing (optional) Gypsum board <p>2. Tape between interior membrane and floor sheathing AB</p> <p>3. Extruded polystyrene blocks with spray foam at edges AB</p> <p>4. Self-adhered membrane lapped onto flashing membrane AB</p> | <p>5. Compatible self-adhered flashing membrane over transition strip and through-wall flashing AB</p> <p>6. Insect screen</p> <p>7. Pre-finished through-wall flashing</p> <p>8. Self-adhered transition strip membrane AB</p> <p>9. Wall assembly</p> <ul style="list-style-type: none"> Cement board (or parge coat) and drain mat 4" (102 mm) rigid mineral fibre insulation Damp-proofing AB Concrete foundation wall 4" (102mm) extruded polystyrene taped seams 3/8" (10 mm) air space Wood framing Gypsum board <p>10. Pressure treated sill plate on gasket</p> |
|---|--|

WALL - FOUNDATION WALL | **DETAIL 4**

INTERIOR-INSULATED DEEP STUD WALL TO SPLIT-INSULATED FOUNDATION WALL

FOR ILLUSTRATION PURPOSES ONLY - NOT FOR CONSTRUCTION

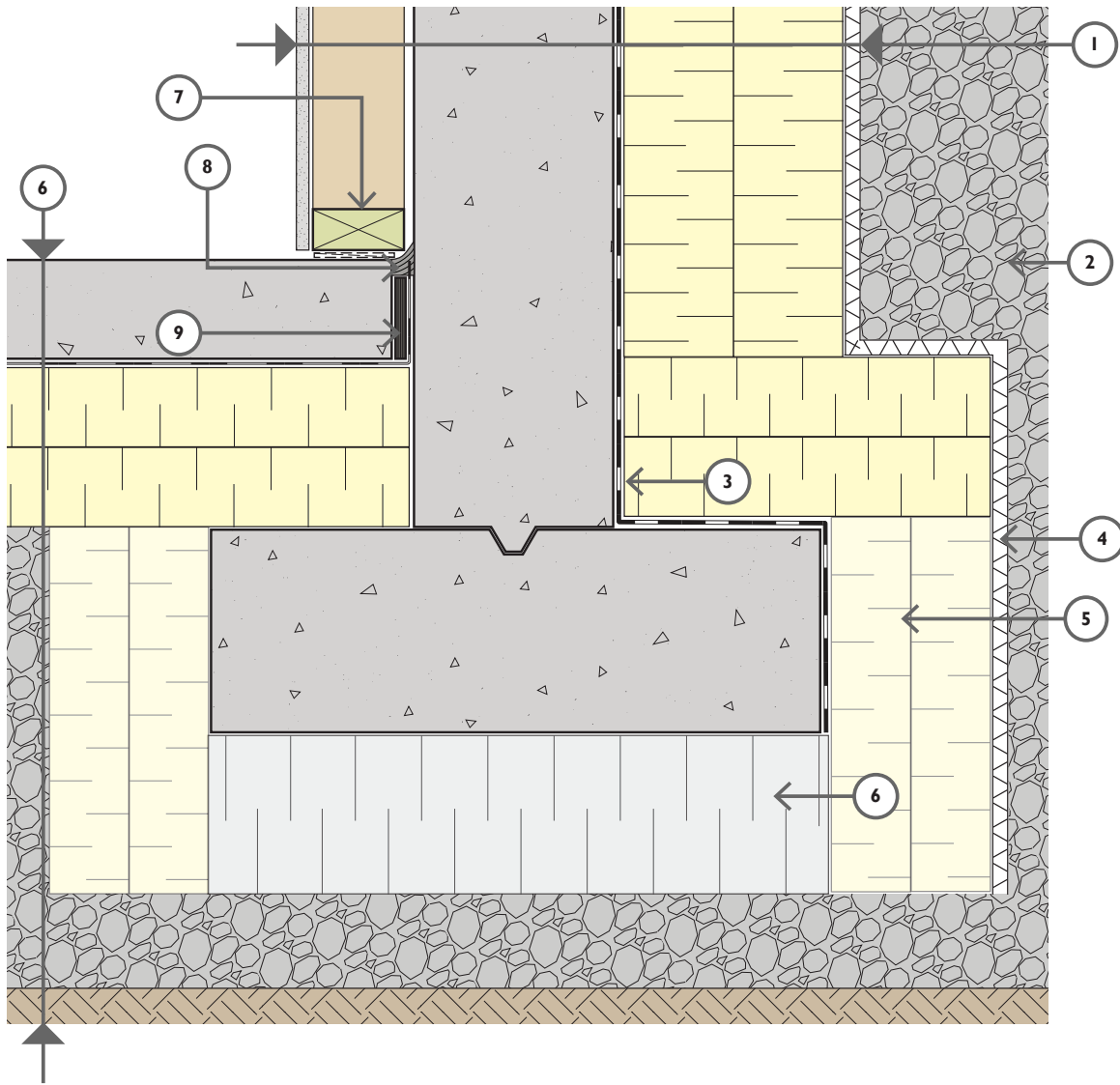

LEGEND

1. Wall assembly
 - Crushed rock backfill
 - Drain mat
 - 8" (203mm) rigid mineral fibre insulation
 - Damp-proofing AB
 - Concrete foundation wall AB
 - 3/8" (10 mm) air space
 - Wood framing
 - Gypsum board
2. Crushed rock backfill around drainage pipe with filter fabric at outside edge (not shown)
3. Compatible damp-proofing membrane applied to concrete foundation wall and footing
4. Drain mat over rigid mineral fibre insulation
5. 6" (152 mm) rigid mineral fibre insulation (optional) (type as structurally required)
6. 6" (152mm) non-compressible rigid insulation (optional) (type as structurally required)
7. Floor assembly
 - Concrete slab AB
 - 9 mil polyethylene sealed at laps AB
 - 6" (152 mm) rigid insulation
 - Coarse, clean granular fill (capillary break)
 - Undisturbed soil
8. Pressure-treated (p.t.) bottom plate on shims
9. Sealant bead between slab & foundation wall AB
10. 1/2" (13 mm) gap between slab & foundation wall filled with asphalt fibre board AB

FOUNDATION WALL - SLAB | **DETAIL 5**

EXTERIOR-INSULATED FOUNDATION WALL TO EXTERIOR-INSULATED FLOOR SLAB

FOR ILLUSTRATION PURPOSES ONLY - NOT FOR CONSTRUCTION

Additional Resources

- › [BC Energy Step Code](#), published by the Government of British Columbia
- › [BC Energy Step Code Builder Guide](#), published by BC Housing
- › [British Columbia Building Code](#), published by the Government of British Columbia
- › [National Building Code](#), published by the National Research Council Canada
- › [Attic Ventilation and Moisture Research Study](#), published by BC Housing
- › [Illustrated Guide - R30+ Effective Vaulted & Flat Roofs in Residential Construction in BC](#), published by BC Housing
- › [Illustrated Guide - R22+ Effective Walls in Residential Construction in BC](#), published by BC Housing
- › [Building Enclosure Design Guide - Wood-Frame Multi-Unit Residential Buildings](#), published by BC Housing
- › [Guide for Designing Energy-Efficient Building Enclosures for Wood-Frame Multi-Unit Residential Buildings](#), published by FPInnovations, BC Housing, and the Canadian Wood Council
- › [Illustrated Guide - Achieving Airtight Buildings](#), published by BC Housing
- › [Framework on Clean Growth and Climate Change](#), published by the Government of Canada